

VTL

---

Siegfried Series II Reference Monoblock Amplifier

*Owner's Manual*

MAKING TUBES USER FRIENDLY

# VTL Siegfried II Amplifier

---

Information in this document is subject to change without notice. No part of this document may be reproduced or transmitted in any form or by any means, electronic or mechanical, for any purpose, without the express written permission by VTL.

Version History:

Version 1.1      April 19, 2012

Part Number: OM-Siegfried

Copyright © 2012 by VTL Amplifiers Inc. All rights reserved.

4774 Murrieta Street, Suite 10

Chino, CA 91710, USA

Phone 909.627.5944 • Fax 909.627.6988

Email: [mail@vtl.com](mailto:mail@vtl.com) • <http://www.vtl.com>

# TABLE OF CONTENT

<b>CHAPTER 1 .....</b>	<b>1</b>
INTRODUCTION.....	1
<i>Symbol Conventions used in this guide</i> .....	4
<i>Electrical Safety Notice</i> .....	4
<i>Water and Moisture</i> .....	4
<i>Location and Ventilation</i> .....	4
<i>Servicing</i> .....	5
<i>Operational Warnings</i> .....	5
<b>CHAPTER 2 .....</b>	<b>7</b>
GETTING STARTED .....	7
<i>Before starting</i> .....	7
<i>Unpacking the unit from the crate</i> .....	7
<i>Changing Top Cover Screws</i> .....	10
<i>Quick Start</i> .....	11
<b>CHAPTER 3 .....</b>	<b>15</b>
OPERATING THE AMPLIFIER .....	15
<i>Rear panel controls and connections</i> .....	15
Rear Panel Functions .....	17
1. Fuse Tester .....	17
2. Changing input between balanced and single-ended.....	17
3. Changing amplifier phase .....	17
<i>Front panel controls and indicators</i> .....	18
Front Panel Controls .....	18
Front Panel Indicators.....	18
<i>AC Voltage Setting</i> .....	19
<i>AC Power Source</i> .....	19
Connection to the AC.....	20
<i>Powering On the Amplifier</i> .....	20
<i>Ground Loop Hum</i> .....	23
<i>Setting the Operating Mode</i> .....	23
<i>Muting the Amplifier</i> .....	24
<i>Tube Bias and Top deck Indications</i> .....	24
<i>Using the DF switches</i> .....	26
DF Switch Settings .....	27
<i>Remote Control and Communications</i> .....	29
Using a 12V trigger to power the amplifier on or off.....	29
Using the Amplifier with an infrared Remote Control.....	30
Using the amplifier with RS232 control.....	30
<i>Diagnostic and programming Functions</i> .....	32
Basic Programming functions.....	32
Basic Diagnostic functions .....	34
Advanced Functions and Diagnostics.....	37
<i>Fault Indications</i> .....	39
Not ready modes.....	40
INVERTed Phase .....	40
TUBE green Fault .....	40
TUBE red Fault .....	41
HEAT Fault.....	42
POWER faults .....	43
Tube Service Reminder.....	44
<i>Reset / Clearing faults</i> .....	44
<i>Powering the amplifier off</i> .....	46
<b>CHAPTER 4 .....</b>	<b>47</b>

CARE AND MAINTENANCE OF YOUR VTL AMPLIFIER.....	47
<i>Break In Period</i> .....	47
<i>Tube Life</i> .....	47
<i>Changing Tubes</i> .....	48
<i>Changing the Screen, Plate, Logic, B+ Input, Filament Fuses</i> .....	51
<i>Cleaning</i> .....	52
<i>Troubleshooting</i> .....	52
<b>CHAPTER 5 .....</b>	<b>55</b>
SPECIFICATIONS .....	55
<b>CHAPTER 6 .....</b>	<b>57</b>
WARRANTY .....	57
<b>APPENDIX.....</b>	<b>58</b>
<i>Appendix I: Quick Reference - Summary of indicators</i> .....	58
<i>Appendix II: Individual tube hour log</i> .....	60
<i>Warranty Registration</i> .....	61
<i>Service Notes</i> .....	61

# Introduction

*Congratulations on your purchase of the VTL Siegfried Series II Reference Amplifier – the modern vacuum tube amplifier designed to bring high performance and ease of use to serious music lovers such as yourself.*

From all of us at VTL, we are proud to offer our Siegfried Series II Reference power amplifier – the ultimate expression of everything we know about power amplifier design, designed to deliver the most advanced technology and thinking in power amplifier design today. Siegfried’s bold and ultra fast sound and commanding vocal and visual presence are appreciated by the most serious and discerning music and film lovers. We thank you for selecting this amplifier for your home audio/theater system, and we wish you many hours of enjoyment for years to come.

In order to get the most benefit from your purchase, we recommend that you take sufficient time to familiarize yourself with the features of this product. Please take a moment to read through this owner’s manual, as it contains all of the installation procedures needed to connect your new amplifier to the rest of your system, as well as the many functions that the *amplifier* can perform. After you have finished reading this manual it should be kept in a safe place for future reference.



## Siegfried – The Myth and the Machine

Who is Siegfried, the Hero?

The Wagnerian character Siegfried is the greatest hero of Germanic and Scandinavian myth, and he knows no fear. The name is a conjunction of ‘victory’(sieg) + ‘peace’(friede). If you think of Siegfried as a sort of Teutonic Achilles, you wouldn’t be far off. He is superhumanly strong, a great warrior, headstrong and nearly invulnerable. As a grandson of Wotan, the most powerful god of Germanic lore, Siegfried has a spark of the divine in him, yet his passion and pride reveal him as fully mortal. Siegfried was raised in the forest away from civilization. He is intuitively sensitive to the ways of the natural world, and exhibits a childlike simplicity in his interactions with others.

What is Siegfried, the Amplifier?

The most advanced member of VTL’s Reference amplifier lineup, the *Siegfried* Reference Amplifier expands the boundaries of what a powerful tube amplifier can be. Directly descended from VTL’s *Wotan* MB-1250 Reference Amplifier, one of the most powerful tube amplifiers in continuous production, Siegfried shines in its own unique way. This 650-watt all-tube monoblock provides all the muscle you’d ever need to handle the most demanding musical passages, but possesses the speed and brilliance of lower powered amplifiers.

Logic-controlled automatic biasing of all tubes means Siegfried constantly checks itself for optimal performance. A full range of diagnostics alerts users to the status of each tube, including when to retube. Siegfried puts an end to the guesswork formerly inherent in large tube amplifiers, while crossing new thresholds of sonic performance.

### The Design Goals and Benefits

When the VTL design team began developing the concepts for a next-generation Reference amplifier, the following design goals were laid out:

- The Reference amplifier should deliver a new sonic standard worthy of its marque as a member of the VTL Reference family – it should provide unsurpassed sound quality into real-world loads, as well as excellent measurements on the test bench
- The amplifier must be able to drive a wide range of speaker types to their optimal performance, with consistent performance under a wide range of conditions
- The amplifier must be self-optimizing and provide a full range of diagnostics for maintaining peak performance and providing user feedback, without the need for the user to have to know the inner workings of the amplifier.
- The operation of the amplifier must be intuitive and user-friendly while providing flexibility in its control functions, for integration with modern home theater systems
- Complete in-system diagnosis via front panel or remote to make remote use and maintenance easy.

These goals have been fully realized in the new Siegfried power amplifiers.

### Siegfried Series II Circuit overview:

An all-tube amplifier, Siegfried is the culmination of VTL’s most advanced thinking in performance engineering, with self-optimization, fault diagnosis and user feedback designed to bring the ultimate performance and convenience to the user.

The Series II version of the renowned Siegfried platform features a complete re-working of the entire signal path. Upgrades include a fully balanced differential input stage driving a differential phase splitter and a lower impedance

push-pull output stage with a dramatically improved, fully balanced and enhanced interleaved and coupled output transformer.

The Siegfried Reference monoblocks gain further sonic benefits with a shorter, faster and fully balanced negative feedback loop, with zero global negative feedback. The negative feedback loop completely eliminates ringing and requires no capacitor compensation to maintain critical phase integrity and information. The result is an amplifier that remains stable even under the most demanding loads.

Adjustable precision-regulated plate, screen and bias supplies hold the output tube operating point constant even under AC and main power supply fluctuations, and stabilizes the critical power supplies yielding tonal stability and sonic integrity especially during complex, dynamic signal conditions.

Another new feature in Series II is a user adjustable Damping Factor feedback control that allows the user to adjust the amplifier's output impedance by varying the amount of negative feedback. Impedance can now be precisely set to suit the listener's taste, and to improve control of the loudspeaker loads to deliver best performance. The 4 possible settings are:

1. LOW -- Lowest damping factor, good loudspeaker control, most natural sound.
2. MED -- Better loudspeaker control, with some impact on sound quality
3. HI -- Best loudspeaker control, with a little more impact on sound quality, but on speakers that need the control the sonic improvement is clear
4. MAX -- Maximum damping factor, but sonic impact is noticeable

Tube life is dramatically extended by optimized operating voltages and timed, low current inrush limiting, with low idle current draw on all stages. An ever-warm position further lowers idle current and keeps all voltages present to keep the circuit warm when not in use.

Comprehensive fault sensing monitors internal and external conditions, protects the circuits, and alerts the user under any adverse conditions. In the case of any malfunction of any of the output tubes the amplifier is shut down to protect the circuitry and faults are indicated on the front panel, along with the blinking LED on the top deck next to the tube that caused the fault shutdown, to make diagnosis and tube replacement easy.

The logic-controlled automatic bias system is designed to keep the tubes at peak performance and operates completely outside of the signal path. The tube biasing circuit checks and adjusts the tube bias values automatically during the power on sequence, as well as when the amplifier is at idle (i.e. when no music signal is being amplified.) and drops out of the circuit path when music signal is detected.

## Symbol Conventions used in this guide

Certain symbols are used in this owner's manual to draw your attention to important points being discussed. For your own safety and that of your equipment you should note and heed the warnings that follow these symbols.

The "Warning - Pay particular Attention" symbol used is



And the "Warning - Observe These Precautions for Your Safety" is



## Electrical Safety Notice

Electrical voltage from power cables can be hazardous. We recommend that the power cord used with this unit be connected to a properly grounded AC outlet. There are hazardous voltages present in the unit, and to prevent electrical shock, do not remove the cover of this amplifier, and under no circumstances while the unit is powered on.



Warning - Under no circumstances should any attempt be made to circumvent the ground system to the AC line for any reason. Using a ground lifted system can be potentially extremely dangerous, both to persons that might come in contact with the unit, and to the unit itself, and proper RF shielding cannot be attained without a secure ground connection.



Damage to the unit that is the result of improper AC connection and grounding will not be covered under the warranty.

Prior to connecting this amplifier to any audio or video equipment in your system, make sure this unit's power (and the rest of the equipment connected to its input and output channels) is turned off. Adding or removing input or output cables to the amplifier while the system is powered on can cause damage to the amplifier and possibly also to the rest of the system.



## Water and Moisture

The amplifier should be kept away from sources of water or moisture. If liquid enters the unit it must be immediately returned to your dealer for servicing. In this case you should under no circumstances try to power the unit on - there are hazardous voltages present in this unit that can cause serious injury if they come in contact with you.



## Location and Ventilation



Warning - To avoid risk of failure due to overheating, do not stack chassis components



The amplifier emits heat and needs proper ventilation to ensure long operational life.

Ensure that the amplifiers are installed in a location that is stable and well ventilated. If the amplifier is placed in a built-in installation, ensure that there is adequate room for air to flow through the ventilation openings. Allow at least 12 inches clearance on the top and around the sides of each chassis of each amplifier. The warranty does not cover units that are damaged due to overheating from incorrect installation.



Tiptoes or other isolation accessories may prove useful in reducing mechanical vibrations or other external vibrations that might affect sonic performance, and we have found that such accessories can offer definite beneficial sonic improvements when used correctly. In all cases you should be sure to install this amplifier in a location that is stable, as warranty does not cover damage due to the unit falling.

Do not place the amplifier next to heat sources such as radiators, stoves or other appliances.

Do not place the amplifier where small children might be able to tamper with the equipment. If it is not possible to place the amplifier out of the reach of small children it is recommended that you remove power cables when the equipment is not in use.

## Servicing



Do not attempt to service the amplifier beyond the procedures described in this manual. For all other service and questions, please contact your authorized VTL dealer or the factory.

## Operational Warnings



→ **It is critical for proper sonic performance of this component that it be properly configured for the mode of operation while playing. If a balanced signal is applied to the inputs the amplifier must be configured for balanced operation, and vice-versa.**



→ Always make all connections before powering the amplifier on. Connecting or disconnecting the amplifier while powered on can damage the output stage, and will not be covered under the warranty. Ensure that no interconnect cables can become loose during use and that there are no intermittent faults with the cables.



**Warning:** The Siegfried Series II amplifier is a fully balanced design with a balanced output. Care should be taken so that neither output is ever grounded.

**Warning:** Do not connect a sub-woofer to the output of the amplifier unless you are sure that the subwoofer input is fully balanced and that neither phase can become grounded.

Please consult your authorized VTL dealer or the VTL factory customer support department if you have any questions on the fully balanced connection of the amplifier.



→ **Do not attempt to disassemble the amplifier chassis or remove any covers from the amplifier.** Always consult with your VTL authorized dealer or the VTL factory support department before attempting any service work on any VTL unit.



→ **Do not touch the tubes after the amplifier is turned on.** Tubes can get very hot while the amplifier is operating. Turn off the amplifier and allow the tubes to cool down before attempting to work with the tubes.



→ Tube components can be heavy and awkward to lift, with the weight unevenly distributed, and you should not attempt to move the unit without help. The amplifier weighs approximately **210 lbs. (95 Kg)**.



→ Do not exceed fuse ratings or attempt to bypass any fuses, as this can cause an extremely hazardous condition and will void any warranties. Use only the same type and rating of fuses as specified in the owners' manual and marked on the unit.

# Getting Started

## Before starting

1. This amplifier is shipped with one monoblock in each crate. Inside the crate the amplifier is wrapped in thick plastic. The plastic is not strong enough to support the unit, and may tear if you try to lift the unit out of the box with it. Also there are protruding switches, which could break if the unit is not properly handled, and in addition to the awkward, unbalanced heavy load the unit has sharp edges and a cleaning polish on it, which makes it slippery and hard to grasp.
2. When lifting the unit, be sure to enlist the help of one or more person(s) to help you. Lift from the bottom of the unit with both hands. Be careful not to break any switches or to rest the unit on any side other than the bottom side, and on a stable surface. Setting it on any other side may damage protruding components.



➔ SAVE THE CRATES AND ALL PACKAGING FOR FUTURE SHIPMENT.

**Warning:** This unit is extremely heavy, and weighs about 200 lbs. Unpacking should be done by two or more people who are capable of lifting a heavy load. Ensure that the amplifier would not fall and injure someone. Do not attempt to lift the unit yourself.



## Unpacking the unit from the crate

1 crate comes with an accessory cover and 1 crate does not have the accessory cover.

Before the crate with the accessory cover can be removed from the base, the top accessory cover must be removed.

Start by removing all of the screws from around the top of the crate. There are 14 screws in all that must be removed before the top accessory cover can be separated from the crate.

Place the screws in a safe place like in a plastic bag or box.

Remove the screw from around the top section of the accessory box.  
There are a total of 14 screws that need to be removed.



Remove top cover to gain access to accessories.  
Remove all accessories before removing entire crate from base.

Once all of the screws are removed, the top accessory cover can be lifted off of the crate. With the help of someone else, lift the top accessory cover off of the crate and set aside for the time being.



After opening the top cover of the crate, you should find the following items inside:

- 4 6-32 x 3/8" socket head screws
- 2 6-32 x 3/8" flat head screw
- 2 standard 20A power cord for the electrical system in the country of operation
- Spare Fuses and 2 spare output tubes
- 2 sets of four spiked feet for each amp
- This Owner's Manual, Quick Reference Sheet, VTL Quality Assurance and test printout, and a VTL product warranty registration card

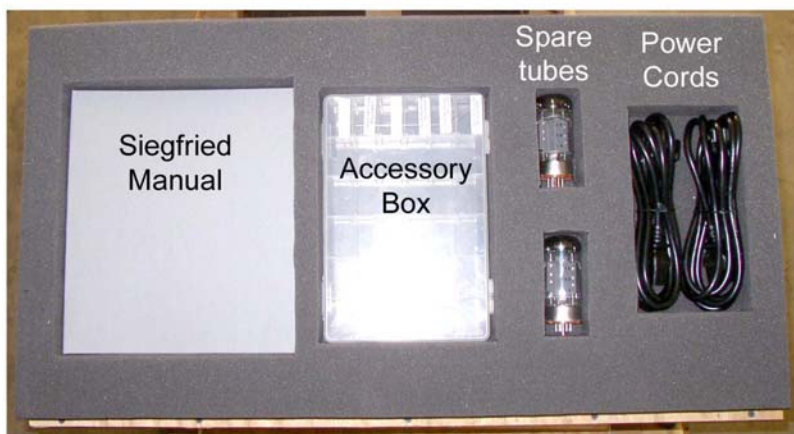

(The following sets of instructions apply to both crates from this point on.)

After removing the top accessory cover, then you may proceed with removing the screws from around the bottom of the crate (all 4 sides, total of 14 screws), and removing the crate box by lifting it straight up over the amplifier as shown in the following pictures, then proceed with the rest of the unpacking process.

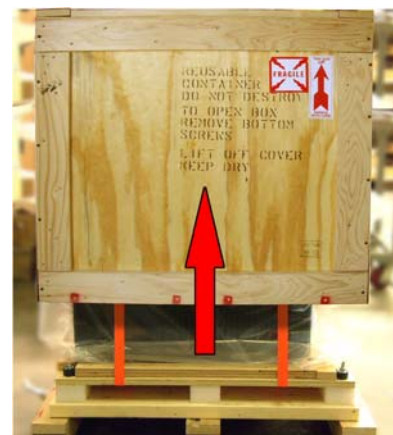
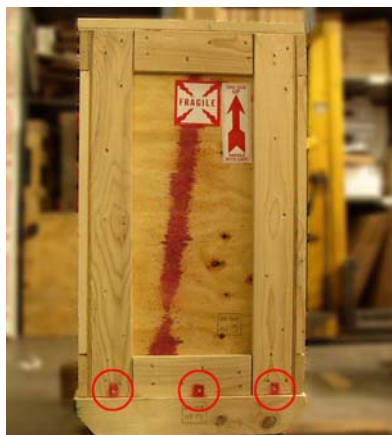

Remove each item from its packaging material and put aside for future use.

3. Remove the tie straps from the unit. Press the release button on the strap tightener and the straps will loosen up. Completely loosen the straps and remove them.

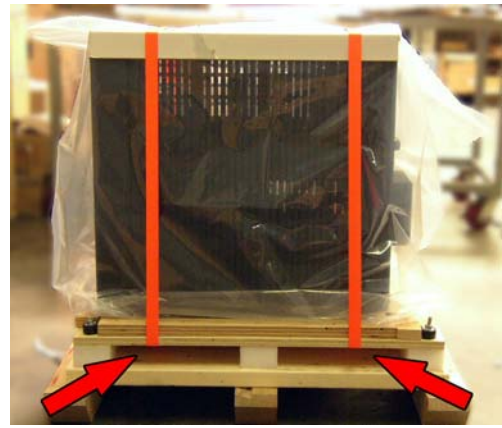

4. Open the plastic bag and pull it down around all sides of the unit, completely exposing the unit.
5. With at least two people, lift the amplifier clear of the bag and the crate bottom, and place the unit on a carpeted floor on the two aluminum feet.



**WARNING:** *Do not lift the unit by the heat sink or you may cause damage to the internal components of the unit.*

6. If you wish to install the spiked feet on the bottom of the amplifier, remove the 4 spiked feet from the Spare Parts kit that was included with this unit. Tilting the unit to one side at a time, install the feet into the threaded holes in the aluminum base of the amplifier, in the approximate locations pictured.

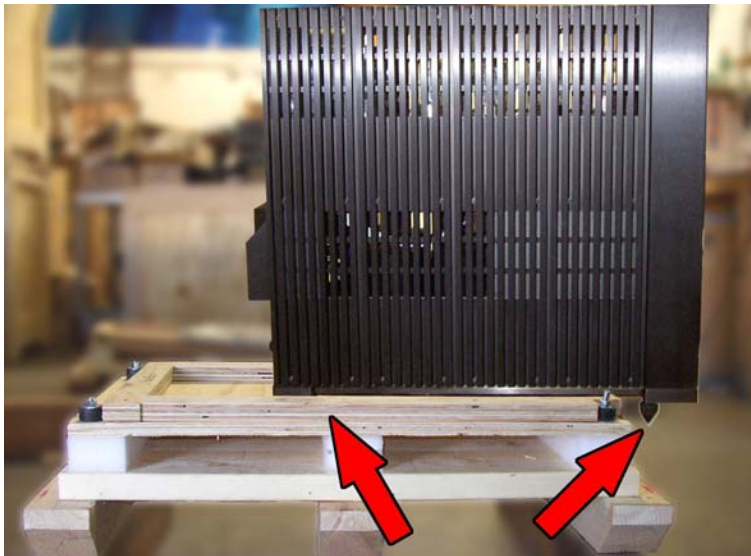

5. Return the plastic bag and the tie straps to the base of the crate, place the crate box onto the base and screw it together with the same screws that were removed during unpacking. Keep the crate in a safe place for future shipping.

Check to make sure that no physical damage has occurred during shipping of the unit. There should be no rattles inside the amplifier chassis. Look through the top cover and check to see that the tubes appear properly seated in their sockets, and that no tubes are white on top. Contact your VTL dealer immediately if any physical damage is detected.

## Changing Top Cover Screws

When the amplifier is first shipped from the factory, the top cover is installed with locking screws. These screws can be removed and replaced once the amplifier is setup in the listening area so that the top cover can be removed easily without any hand tools.

Once the locking screws are removed, please put them in the Spare kit that came with the amplifier. You will need to put these screws back when shipping or moving the amplifier to ensure that the top cover is securely fastened.

The top cover of the amplifier is fitted with long screws (6-32x5/8 Phillips head and 6-32x7/8 socket head) in three strategic locations along the top cover. To remove the top cover, these three screws must be removed first. Two of the long screws (socket heads) are located on the right side panel, screw #2 and #7 counting from the side closest to the front panel. The third screw (Phillips head) is located on the top right hand corner of the back panel.

After the three long screws are removed, gently lift up the top cover. Enclosed in the spare package are the shorter replacements screws. Replace the right side panel #2 and #7 screws with two 6-32x3/8" socket head screws. Replace the back panel screw with the 6-32x3/8" flat head screw. Tighten the screws without overdriving them. Put the top cover back onto the amplifier. You can now remove or replace the top cover easily without using any tool.

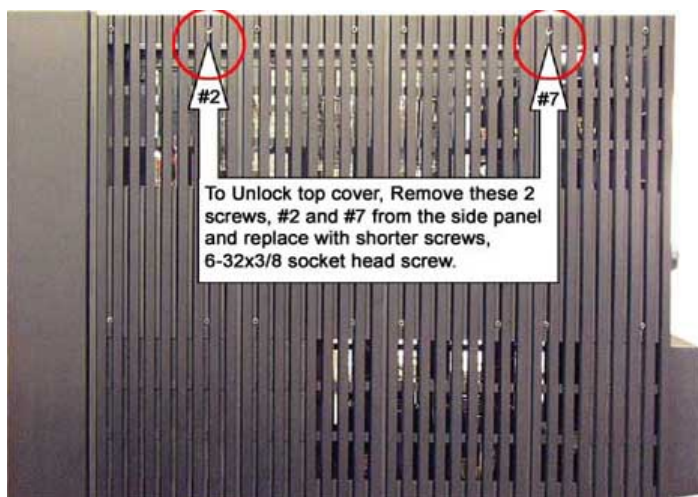

**WARNING:** there are high temperatures and hazardous voltages inside the unit. If any household members might accidentally be exposed to these temperatures or voltages, then the cover shipping screws should be left in place to prevent accidental removal of cover.



Locations of the Top Cover Screws on the back and side of the Amplifier



Opening the protective cover can expose potentially lethal voltages. Be sure to remove the top cover screws when the amplifier is turned off, and do not allow any part of your body or hanging jewelry to touch the inside of the amplifier.

## Quick Start

As the proud owner of your new amplifier, you are probably keen to connect it into your system and listen. This section is a quick setup-up guide to help you get started in the shortest time possible.

Once the amplifier is in your system and operational, please take the time to read the rest of the information in this manual. It will give you the in-depth perspective into all the functions your amplifier is capable of delivering and how to take advantage of the many sophisticated functions built into your amplifier to inform you of its internal status.

Step 1: Find a location for the unit.

We recommend that this amplifier be placed in a stable, dry location that is well ventilated. Note that for proper ventilation the amplifier requires sufficient air space on top as well as around its sides.

Briefly check into the cage and ensure that no tubes are out of their sockets or white on top.

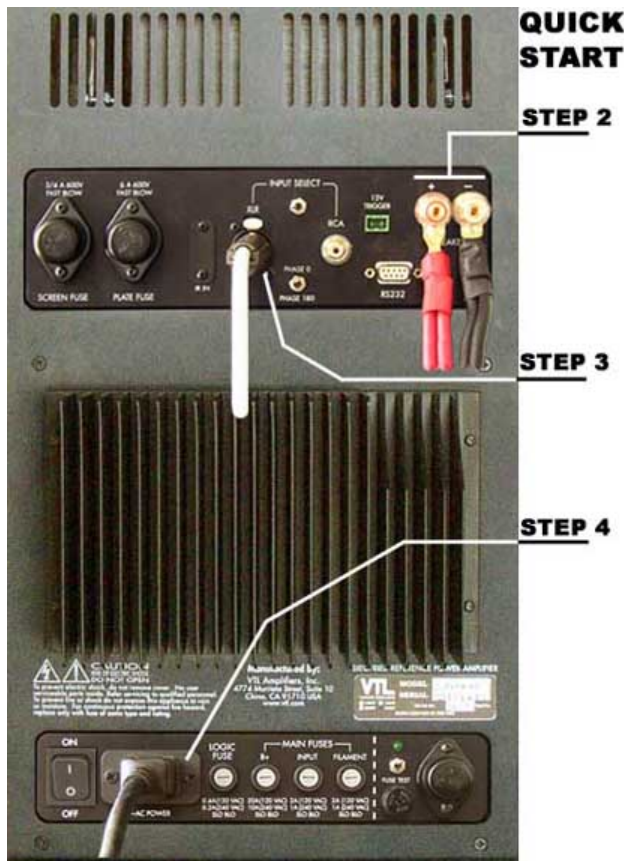

Step 2: Connect the Amplifiers to the Loudspeakers

Connect the loudspeaker cable from each speaker to the rear 5-way speaker binding post on the corresponding amplifier. Use a 7/16" wrench to tighten the binding post nut, taking care not to over-tighten the binding post. Check to make sure that the connections from the speakers to the amplifier's binding post are correct: + (or red) to + and - (or black) to -



**Warning:** The Siegfried Series II Amplifier is a fully balanced design with a balanced output. Care should be taken so that neither output is ever grounded.

**Warning:** Do not connect a sub-woofer to the output of the amplifier unless you are sure that the subwoofer input is fully balanced and that neither phase can become grounded.

Please consult your authorized VTL dealer or the VTL factory customer support department if you have any questions on the fully balanced connection of the amplifier.

Step 3: Connect the Preamplifier to the Amplifier

Make sure all units are turned OFF, connect the preamplifier's output to the amplifier's input, matching the left and right channels. If your preamplifier supports balanced output and you have balanced interconnects, connect the preamplifier's balanced output to the power amplifier's balanced input, with the right channel output from the preamplifier going to the input of the right amplifier, and similarly the left channel output of the preamplifier to the input of the left amplifier.



If you are connecting to the power amplifier using single-ended interconnects, connect the preamplifier's RCA/single-ended channel output to the amplifier's single-ended input, making sure the left channel of the preamplifier is connected to the left amplifier, and so on.

#### Step 4: Connect the amplifier to the AC outlet

Before connecting to the AC, make sure that the *Power* rocker switch on the back of the amplifier is turned OFF. Locate the 20A IEC power cord included with this unit, and connect the square end of the power cord to the AC Power inlet located in the back of the amplifier (near the bottom) and the other end of the power cord to the AC outlet on the wall. The plug should seat all the way into the connector, as loose connections can cause intermittent operation.

#### Step 5: Select the correct input

Set the *Input Select* switch on the back of the amplifier to either XLR or RCA, according to the type of interconnect cable being connected, as shown above.

**Warning: It is critical for proper sonic and noise level performance of this component that it be properly configured for the correct mode of operation. If a balanced signal is applied to the inputs the unit must be configured for XLR/balanced operation, and vice-versa.**



#### Step 6. Power on the Preamplifier and source(s)

Power on the preamplifier. Make sure that your preamplifier is either in the mute state or turn its volume to the zero position.

Before turning on the System, make certain that all connections are made firmly, with the correct channels connected and phase settings, and that all switches are in the correct position.



#### Step 7. Turn on the Amplifier

Locate the *Power* rocker switch at the back of the Amplifier on the bottom right hand corner next to the AC power inlet. Turn the switch up to the "ON" position. For the first 10 seconds, you should see four dots scrolling on the display window indicating that the amplifier is checking its internal status and when it is ready to go into the standby mode, four blue bars "----" will be displayed in the amplifier's numeric *Display* window, indicating that the amplifier is now in standby mode ready for the power on command.

Locate the red POWER button on the front panel located beneath the display window in the center of the Amplifier. Push and release the POWER button once to turn on the amplifier. The blue light above the red POWER button will start to blink, and the display window indicates the power on countdown sequence, starting from 240.

During the power up countdown period, the amplifier is in MUTED mode and has no output, as indicated by the red MUTE light. The amplifier goes through its internal warm-up stage and the output tubes are automatically biased during this period, until all tubes reach their optimum bias value.

At the end of the power-on countdown period, the POWER light changes to a steady blue and the MUTE light is turned off, indicating that the unit is now ready to receive signal.

The Mode LED is steady green if the amplifier is in Tetrode mode (red if in triode mode). The default Mode setting is green for Tetrode mode.

If optimum bias values are not reached by countdown 000 then the mute led will start to blink, and the 000 will stay on the display until proper bias values are reached, after which time both the 000 display and the MUTE light will be turned off, indicating that the amplifier is ready to receive signal.



Check that modes are the same on all channels, and that all channels are in phase (ie both showing the INVERT indication on the front panel, or both not showing the INVERT indication, depending upon the preamplifier used.)

**Congratulations! You have just completed the Quick Start section for your new amplifier's operation. You may now wish to read the rest of this manual while relaxing and listening to some of your favorite music.**

# Operating the Amplifier

## Rear panel controls and connections

There are two main panel areas on the back panel of the amplifier chassis:

- The top rear panel is the Input/Output interface panel and also contains the DC rail fuses.
- The bottom rear panel is the Fuse/AC panel and houses the AC Power inlet, input fuses and the fuse tester.

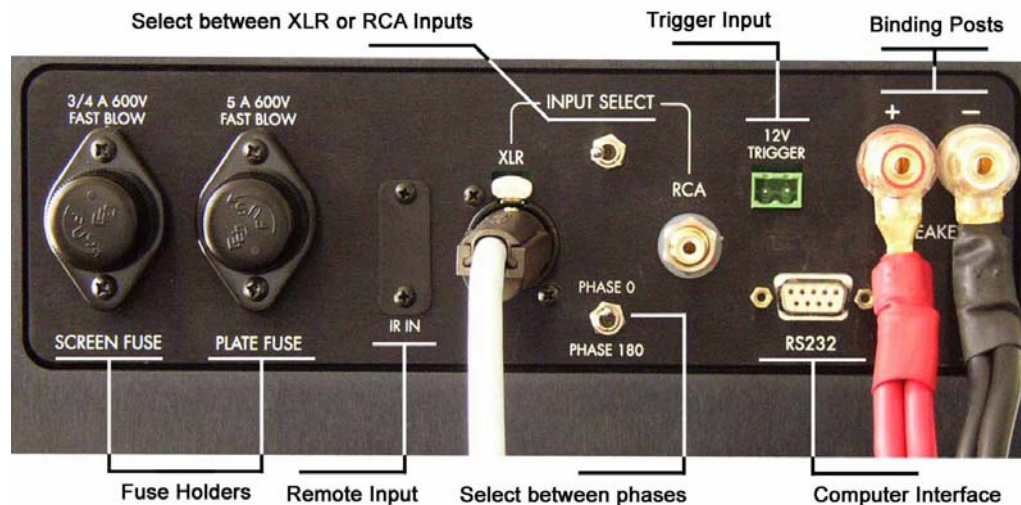

Input/Output Interface Panel

The **Input/Output Interface Panel** contains the following:

➔ The *Screen Fuse* is the output tube's screen fuse.

➔ The *Plate Fuse* is the output tube's plate fuse.

**CAUTION: High voltages present. For continued protection against risk of fire replace only with fuses of same type and rating.**



➔ The *IR Receiver* is used for receiving infrared signals from an external remote extender or central remote system.

➔ The *Balanced XLR input jack* is for receiving a balanced signal from the source/preamplifier.

➔ The *Input Select switch* is used to select the correct input. Move the handle towards the input to be selected.

➔ The *Phase select switch* is used to select the input signal phase. Switch up for Phase 0 (Normal) and down for Phase 180 (INVERTed).

→ The single ended *RCA input jack* is for receiving a single ended signal from the source/preamplifier.

**CAUTION:** For best performance do not connect both single ended and balanced cables at the same time.



→ The *Trigger Input* accepts an electrical signal command from an external component to remotely power up or power down the amplifier. (6V to 24V, AC or DC)

→ The *Speaker Binding Post* is used to connect a loudspeaker to the amplifier. (Please note the correct phase when connecting to the loudspeaker: Red (or +) to +, and Black (or -) to -.



**Warning:** The Siegfried Series II amplifier is a fully balanced design with a balanced output. Care should be taken so that neither output is ever grounded.

**Warning:** Do not connect a sub-woofer to the output of the amplifier unless you are sure that the subwoofer input is fully balanced and that neither phase can become grounded.

Please consult your authorized VTL dealer or the VTL factory customer support department if you have any questions on the fully balanced connection of the amplifier.

→ The *RS232 connector* allows a bi-directional connection between the amplifier and a computer or central remote system via a standard Male to Female DB9 RS232 cable, and will accept remote commands from the computer and communicate operating status and diagnostic information back to the computer.

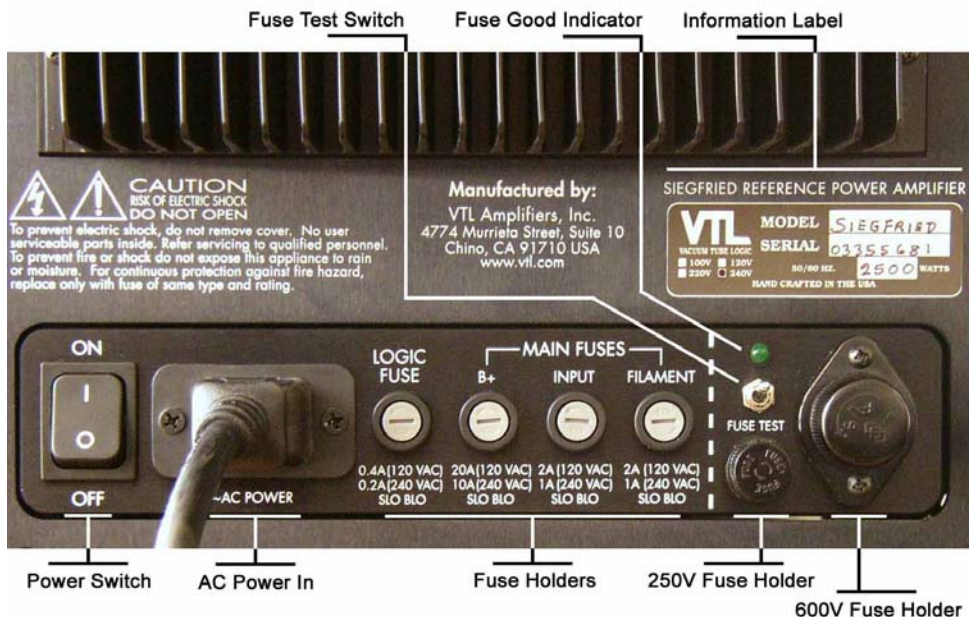

Fuse/AC Rear Panel

**The Fuse/AC Panel contains the following:**

→ *Information label* contains the serial number, with date of manufacture (year and week in the first 4 digits) and voltage and power consumption information.

→ *Power Rocker* switch: Turns the amplifier on into the Standby mode. Press up for Standby, and down for completely powered off.

- ➔ *AC Power Inlet*: Used for connecting the amplifier to the AC power from a wall outlet, using the appropriate 20A power cord.
- ➔ *Logic Fuse*: AC fuse for the universal logic power supply.
- ➔ *B+ Fuse*: AC fuse for the B+ and bias power supply transformer.
- ➔ *Input Fuse*: AC fuse for the input and driver stage B+ power supply transformer.
- ➔ *Filament Fuse*: AC fuse for the Filament power supply transformer.

**CAUTION: High voltages present. For continued protection against risk of fire replace only with fuses of same type and rating.**



- ➔ *Fuse Tester*: For testing whether any fuse is good or blown.

## Rear Panel Functions

### 1. Fuse Tester

Since the fuses used in this amplifier do not show visible indication between good or blown, the fuse tester facilitates testing of both of the two different types of fuses used in the amplifier. See the Fault section in this chapter for directions of use.

### 2. Changing input between balanced and single-ended

To change the input mode between single-ended and balanced move the *Input Select* switch in the direction of the input to be used. There is no front panel indication of the input mode being selected.

**WARNING:** It is critical for proper sonic performance of this component that it be properly configured for the correct mode of operation. If a balanced signal is applied to the inputs, the unit should be configured for balanced operation, and vice-versa.



Since the two inputs differ in gain, for proper channel balance it is recommended that all amplifiers in the system be set to the same input.

**WARNING:** This is a very high-powered amplifier, capable of extremely high levels. Do not change cables or the Input select switch while the amplifier is in operate mode, as speaker and amplifier damage may result. Turn off all components before plugging or unplugging any cables into either amplifier input.



### 3. Changing amplifier phase

Some preamplifier and source components invert phase by design, and in some cases balanced outputs might be phase inverted. In some countries pin 2 of the XLR connector is positive (US standard) and in other countries (e.g. Japan) pin 3 of the XLR connectors is positive. When plugged into a VTL component a pin 3 positive configuration would cause phase inversion, as all VTL equipment with balanced connectors observes the US standard of pin 2 positive.

*Please note that all VTL products are designed to work in 0 or positive phase when in Phase 0 mode, and the amplifier should be set to the Phase 0 mode when using a VTL preamplifier in the system.*

When using a phase inverting design, instead of having to change the speaker cables from + to -, switch to Phase 180 (INVERTed) and set the amplifier to phase inverting from the input to the output by pressing the Phase switch on the rear panel down. The front panel indicator shows the red INVERT light when the amplifier is set to the Phase 180 (INVERTed). To switch to *Phase 0* (Normal) and set the amplifier to phase correct from input to output, lift the Phase switch up. The front panel light is off when set to Phase 0 (Normal).

## Front panel controls and indicators



### Front Panel Controls

There are three visible buttons on the front panel which can perform the most common control functions for the amplifier. Each button is labeled and also has a corresponding light to display the status of the button:

- **POWER:** The red POWER button in the middle of the row is used to toggle the amplifier between power on or off, from and to the standby mode. The POWER light flashes blue during power up, and glows steady blue when powered up into operating mode.
- **MODE:** The MODE button on the left of the row is used to select the operating mode of the amplifier, either Tetrode mode (green light) or Triode mode (red light). The MODE can be selected while the amplifier is in operating mode only.
- **MUTE:** When the amplifier is powered up, pressing the MUTE button on the right of the row toggles the amplifier between MUTED, low current state (no output), indicated by a steady red MUTE light, and operating state, when the light is off. During the unMUTE process the MUTE light flashes red until the amplifier is getting ready to automatically unmute.

### Front Panel Indicators

The *Display window* above the buttons contains the numeric display and a group of five text indicators. The backlit text is not visible unless either activated by the user or by the amplifier to indicate status. The signaling convention used is red for critical warning and green for non-critical warning, while flashing indicates a fault serious enough to require immediate automatic amplifier shut down. The five text indicators and their meanings are as follows:

- **INVERT** (Steady red): Indicates the phase status of amplifier, as set by the rear PHASE toggle switch. The INVERT indicator is off when the input signal is PHASE 0 (normal) and the INVERT indicator turns red when the PHASE switch is set to Phase 180 position.
- **TUBE** (Steady green): Indicates a non-critical tube fault in the tube whose number is indicated on the display. The amplifier continues its current operation.
- **TUBE** (Flashing red): Indicates a critical tube fault in the tube indicated on the display, requiring immediate shut down of the amplifier, and not allowing re-power until the tube is changed and the fault is reset.
- **HEAT** (Flashing red): Indicates amplifier overheating due to high sustained power or insufficient ventilation, requiring immediate shut down of amplifier, and not allowing re-power until the amplifier cools and the fault clears.
- **POWER** (Flashing or steady red, depending upon fault): Indicates either internal or external power supply fault, requiring immediate shut down of amplifier. Steady red means that re-power is allowed, and flashing red means that re-power is not allowed until the fault clears (or is reset, depending upon fault type.)

See the Fault Indication section for a complete description of these fault indicators.

## AC Voltage Setting

This component has been preset to the correct AC voltage for the country where purchased, and is not user or field re-settable. The voltage setting is marked on the serial number badge located on the rear panel of the amplifier. If the marking has been defaced or removed then contact the factory before connecting this component to any AC voltage source.



**WARNING:** Check to make sure that the voltage setting is correct for your local voltage rating before plugging in and turning on the amplifier, as unsafe conditions could be created with incorrect voltages, and damage to the amplifier can result. Damage resulting from improper voltages is not covered under the warranty.

However damage to this amplifier is unlikely, as it is as well protected as possible against operation at incorrect AC voltages, with automatic sensing of the incoming AC voltage and programmed capability to automatically shut down under adverse AC voltage conditions. An internal universal switching supply powers the master processor, which will operate at any input voltage between 85VAC and 260VAC, allowing the master processor to sense the incoming AC voltage and compare it to the internally preset AC voltage setting. If the amplifier's preset voltage range does not match the AC line voltage, the amplifier will not go through the power up sequence, and if powered up then the amplifier will automatically shut down and the front panel display will flash the numeric voltage that the amplifier is set for.

Please contact your authorized VTL dealer or the VTL factory if the AC voltage is flashing on the front panel display.

## AC Power Source

This component is a high-performance, extremely high-powered component, capable of extremely high resolution and sonic performance. To assure best conditions for optimal results, the unit should be plugged directly into a wall AC outlet. Do not plug this amplifier into an extension cord or into the back of another component, as this will starve the

amplifier of current and significantly impact the performance of your system. To achieve the best performance, we recommend that a dedicated 30A line be installed for each power amplifier, with a minimum of 20A required for each amplifier.

We recommend that you consult your authorized VTL dealer or a licensed electrician on the installation of a dedicated line and grounding requirements, as different local codes may apply to your location. See the **Specifications** in chapter 5 for the power consumption requirements of this amplifier.

#### Connection to the AC

Using the supplied 20A power cord, connect the amplifier directly to the AC outlet closest to the chosen location. For electrical safety, ensure that the AC connector fits securely, both to the AC line and to the amplifier's AC inlet, as a loose connection could cause intermittent operation and could damage the amplifier.

Power line conditioners are not recommended for powering this amplifier, as it can draw very high instantaneous peak currents.



**WARNING:** Under no circumstances should any attempt be made to circumvent the AC ground system for any reason. Using a ground lifted system can potentially be extremely dangerous, both to persons that might come in contact with the unit, and to the unit itself, and proper RF and static shielding cannot be attained without a secure ground connection.

This amplifier contains static sensitive components, and damage to the unit as a result of either improper AC connection or improper grounding will not be covered under the warranty. The sensitive microprocessors in this component can be affected by external noise, and proper operation cannot be guaranteed without a noise-free AC ground connection setup for the amplifier.

## Powering On the Amplifier

Please refer to the **Quick Start** section in Chapter 2 on how to properly connect the source, preamplifier and loudspeaker components to this amplifier before powering on.

1. If you haven't already done so, ensure that all the tubes inside the amplifier are properly seated all the way into their sockets before powering on the amplifier. Look through the top cover of the amplifier. There are three shorter tubes in the front that are the input/driver tubes, followed by three rows of four output tubes. If any of the tubes are not fully seated into their sockets, they should be reseated firmly before powering on. If any of the tubes are white on top they should be replaced before powering on. In either of these cases notify the dealer that installed the amplifier, and give the technician the instructions in the Tube Replacement section in Chapter 4 to remove the top cover and reseal or replace the tubes.
2. If the tubes are verified to be fully seated then power on the source component(s) to be used for your listening session
3. Check to ensure that the *Input Select* switch in the back of the amplifier is correctly selected for the interconnect cable being used between the source/preamplifier and this amplifier, i.e. Single ended RCA or Balanced XLR. For equal channel output all amplifiers in the system should be set to the same input type.
4. Locate the Power rocker switch on the lower right hand corner of the amplifier's rear AC/Fuse panel and press the rocker power switch up to the On position. After a 10 second waiting period as indicated by the scrolling periods on the display window, the front panel displays a steady ----, indicating that the unit is now in Standby mode and ready to receive the power on command.



At this point the amplifier is also ready to receive and process ASCII text commands through the rear RS-232 port. The RS-232 commands are listed next to the front panel commands in this manual, and for further explanation and a summary of all of the RS-232 commands available and the expected responses see the section in this chapter on Remote Control options.

If the Display Window shows either a flashing ---- or a numeric value and one of the red back-lit text indicators is turned on indicating some type of fault in the system, the amplifier cannot be powered on. In this case please refer to the Fault Indications section in this chapter and contact your authorized VTL dealer or the factory for assistance.



**Amplifier in Standby Mode**

Front Panel indication: Standby mode

5. If the display shows the steady ----, the amplifier can be powered on via one of the following methods:

- ➔ The red POWER button on the front panel
- ➔ An external trigger source, (such as one of the ones on the VTL TL7.5 Reference Line preamplifier) connected to the amplifier's 12V TRIGGER connector on the rear panel
- ➔ Remote turn on via the IR receiver port. (There is no remote wand supplied with this unit, so please consult with your authorized VTL dealer on the installation and programming of an appropriate IR emitter device.)
- ➔ Power on command issued by a computer or other remote control system connected to the RS-232 port of the amplifier. (Please consult with your authorized VTL dealer on the installation and programming of the RS-232 interface to this amplifier.)

7. If using the front panel POWER button, when the amplifier is in standby mode, (as indicated by the steady blue ---- on the display window) turn on the amplifier by pressing and releasing the red POWER button once. The blue POWER light starts blinking as the amplifier goes through its countdown and power up sequence. The amplifier can be powered off at any time by touching the POWER button once again, where

the blue POWER light turns off, and the amplifier goes back to the standby mode with the Display Window showing the steady ---- standby mode signal.

RS-232 commands: >POWER ON for powering on the amplifier, and >POWER OFF for powering off the amplifier

The power on warm up sequence takes approximately 240 seconds, with the countdown status displayed on the numeric *Display Window* (if not suppressed). This process uses an advanced microprocessor controlled timing technique to enhance tube life by warming the tubes up slowly and applying the high tension with a gentle ramp up, only after the tubes are properly warm and ready to conduct. The autobias system biases the tubes into cutoff and the fault sensing system monitors continuously for faults.

During this warm-up period the amplifier is in the muted mode, and will stay in the muted state until all the output tubes are biased properly. If powering on for the first time after clearing the stored bias values, the bias process can take longer than the indicated 240 seconds, in which case the counter will stop at 000 and the MUTE light flashes while the bias process is being completed. This process can take up to 60 seconds after 000.



Amplifier in Power On Countdown Mode

8. After the power on warm-up sequence is completed, the amplifier automatically goes into the operate state. The POWER light turns into a steady blue light and the MUTE light turns off, indicating that the amplifier is ready to receive audio signal.

The MODE light will be either steady green (for Tetrode mode) or red (for Triode mode), depending on the mode selected before power up.

Caution: This is a very high-powered amplifier, capable of extremely high levels. To protect your system from high signals that might damage the system, before the amplifier finishes the power up sequence ensure that the sources are not playing and that the volume level is adjusted to low.



## Ground Loop Hum

If a ground loop hum comes from the system after installation and power up the amplifier should immediately be turned off and the VTL dealer or the VTL factory should be contacted.



**Caution:** Under no circumstances should any attempt be made to lift or defeat any grounds on any electrical equipment plugged into the AC, as these grounds are installed for safety. Ungrounded components can present an extremely hazardous condition and is illegal under most electrical safety codes. For your own safety please refer all questions of this nature to a properly trained service technician.

## Setting the Operating Mode

The MODE button is located on the left side of the row of control buttons and is used to toggle the amplifier between the triode and tetrode modes of operation. The default mode setting is tetrode mode, indicated by the green light over the MODE button. The MODE can be changed while the amplifier is powered on, as the process is handled automatically after the user initiates the command. The MODE light changes to red when the amplifier is in Triode mode.

The two modes are different in output power and voltage gain, with tetrode mode being the higher of the two. Tetrode mode is typically used for large scale symphonic, rock or big band music, to provide the proper resolution and power required, and triode mode is typically used for smaller scale quartets, chamber music or solo vocals to provide a more intimate sound.

Each user's tastes may vary, and it is not suggested that either one mode or the other necessarily be used as described above, however for proper channel balance all amplifiers in the system should be set to the same mode. Also, loudspeakers requiring higher power in large rooms may negate the use of the lower power triode mode. (See the specifications in Chapter 5 for the power ratings in each mode.)

When the amplifier is in the operate state, pressing the MODE button will cause the MODE light to start blinking as the amplifier goes through the automatic changeover process, going from one mode to the other. For example, if the amplifier is in tetrode mode and needs to be changed to the triode mode, pressing the MODE button will cause the MODE light to blink green until the changeover occurs, after which time the MODE light will change to red to indicate the triode mode. During the changeover period the input is muted, as no signal can pass during this period. (See the section on remote commands for other ways to change the operating Mode of the amplifier.)

**NOTE:** It can take up to 8 minutes to complete the mode change process, during which time the user may safely power the amplifier off if necessary. The mode that the amplifier will re-power up in will depend on how far into the changeover process it got before the power was shut off.

RS-232 commands: >MODE TET for tetrode mode, and >MODE TRI for triode mode.

## Muting the Amplifier

The MUTE function mutes the input of the amplifier, and biases the output stage into a low current state, preventing any signal from flowing through the unit. The amplifier automatically unmutes after finishing the power up process, and the normal operating mode is with the MUTE light off. The MUTE function should be used before turning on or off any upstream components, as pulses could get through the system otherwise, and be amplified by the amplifiers, which could damage the loudspeakers.

The front panel MUTE button is located on the right of the row of control buttons and is used to toggle the amplifier between the MUTED and unMUTED states. If the amplifier is currently in muted state, with the red MUTE light on steady, pressing the MUTE button changes the unit into the operating state, and the MUTE light blinks while the amplifier returns to full bias. The red MUTE light turns off when unit is biased to full idle bias and ready for signal.

RS-232 commands: >MUTE ON for mute and >MUTE OFF for unmute.

The mute function can also be used as an ever-warm function, avoiding the need to turn the amplifiers on and off between listening sessions, and lowering circuit component stress from current inrush. In this state all voltages are at their prescribed levels, with the output stage biased into a low current draw level. In the MUTED mode the heat output is therefore substantially lowered, to a point that saves power and uses very little tube life, and is still sufficient to keep the amplifier warm and ready to come up to full power within 30 seconds.

Leaving the amplifier in the MUTED state for short periods between listening sessions extends tube and circuit life, as with the low trickle current of the output stage the tube life is not substantially reduced in this mode, and the amplifier will be warm and ready for use far quicker after being brought out of the MUTED state than from a cold start. (For longer periods between listening sessions the amplifier should be powered OFF.)

## Tube Bias and Top deck Indications

This amplifier is designed with a unique and sophisticated logic-controlled automatic bias and fault-sensing system to keep all tubes operating at peak performance and to protect the amplifier circuitry at all times. The tube biasing circuit checks and adjusts the tube bias values automatically during the power on sequence, as well as when the amplifier is at idle (i.e. when no music signal is being amplified,) and drops out of the circuit path when music signal is detected. The autobias system also checks and adjusts the bias in between music passages, and so keeps the output tubes operating optimally at all operating temperatures.

The fault sensing system monitors the output tubes and other critical circuit conditions at all times when the amplifier is powered up. In the case of any malfunction of any of the output tubes the amplifier is shut down to protect the circuitry and faults are indicated on the front panel, along with the blinking LED on the top deck next to the tube that caused the fault shutdown, to make diagnosis and tube replacement easy. The new tube is then automatically re-biased to the prescribed level on the next power up, requiring a minimum level of user knowledge about the operation of the amplifier.

Looking down at the deck of the amplifier through the top cover, there is a green LED visible next to and behind each 6550/KT-88 output tube. These LEDs are for identifying the output tubes, and if not

suppressed are normally lit when the amplifier is powered on and in the operating mode, and sometimes blink on and off to indicate bias status.

In the case of a tube fault, whether normal bias LED activity is suppressed or not, the relevant tube's LED flashes quickly to identify the tube that needs replacement, and during diagnostic functions these LEDs are also used to identify the tube(s) being tested.

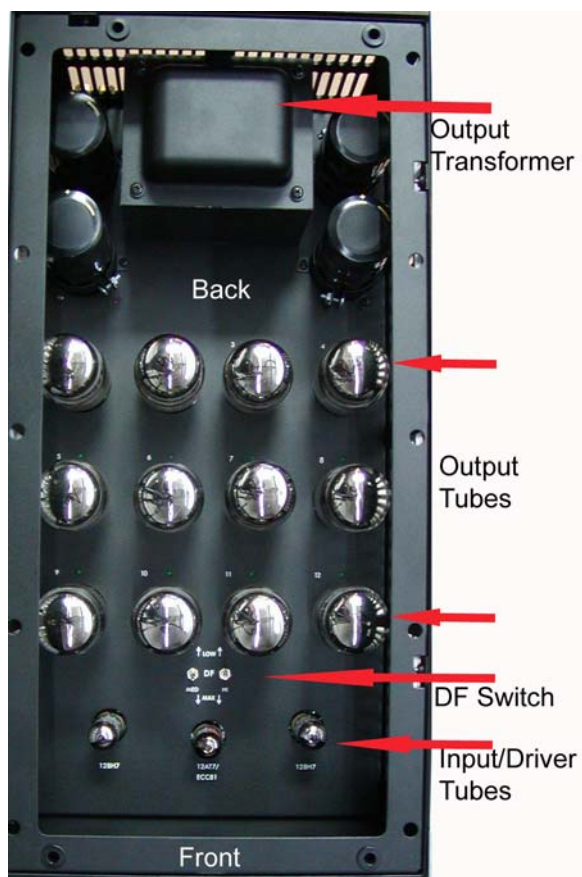

The top deck tube LED indications are as follows:

Output Tube LED Status	Indication
Amplifier is in idle mode with no signal applied and tube LEDs are on steady.	Output tubes are operating at optimum bias setting, and the autobias is holding the bias settings steady.
Amplifier is in idle mode and tube LEDs are flickering on and off intermittently.	The autobias is changing the tube bias settings to the optimum setting.
Music signal is applied and tube LEDs are all off.	The autobias is out of circuit to allow the output tubes to properly amplify the audio signal.
One tube LED is blinking steadily and the green front panel TUBE light is on. (The	The autobias system has detected that this tube is too low and cannot be biased. User should replace

Display Window shows the tube number.)	the tube as soon as possible at the end of the listening session.
One tube LED is blinking rapidly and the red front panel TUBE light is flashing. (Display Window shows tube number.)	The Auto-bias has detected that this tube has a critical fault and the amplifier has been shut down. Replace faulty tube and reset the Tube fault. (See Chapter 4)
The amplifier is in idle mode and tube LEDs are all off.	Normal output tube LED display activity is suppressed. See Basic Programming Functions in this chapter.

The following diagram shows the layout of the tubes on the top deck and the tube numbering system, which corresponds to the tube numbers displayed on the front panel in the case of tube fault, or diagnostic identification:



Amplifier Deck with Bias LEDs

## Using the DF switches

The variable DF is an adjustable Damping Factor control that allows the user to adjust the output impedance of the amplifier.

The two sets of DF switches are located on the deck of the amplifier in front of the 12AT7 tube. Please remove the top cover of the amplifier to access the switches. Always mute the amplifier prior to changing the setting of the DF switches.



There are four possible settings of the DF switches: **Low, Medium, High and Max.** Please check to make sure that the switches in both amplifiers are in the same position. There is no right or wrong position, and the switches are provided to allow adjustment to better suit the listener's taste and to offer better control to loudspeakers that may need it.

#### DF Switch Settings

1. **LOW:** Both switches are positioned towards the back of the amplifier. This is the lowest damping factor setting, the least loudspeaker control, and most natural sound.

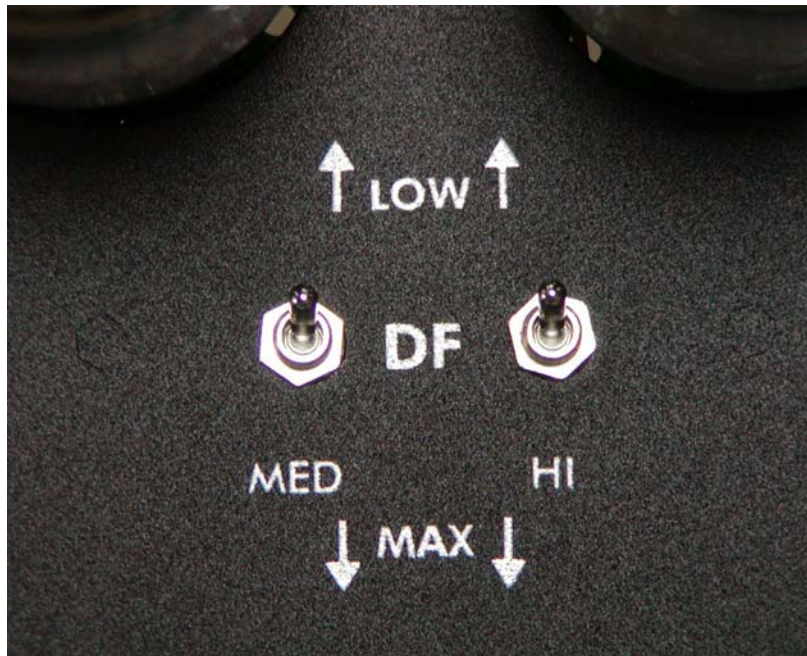

**LOW DF setting**

2. **MED:** The Left switch forward towards the front panel, and the right switch back towards the back of the amplifier. This setting allows for better loudspeaker control.



**MED DF Setting**

3. **HI:** The Left switch back towards the back of the amplifier and the right switch forward towards the front panel. Best loudspeaker control, with a little more impact on sound quality, but on speakers that need the control the sonic improvement is clear.

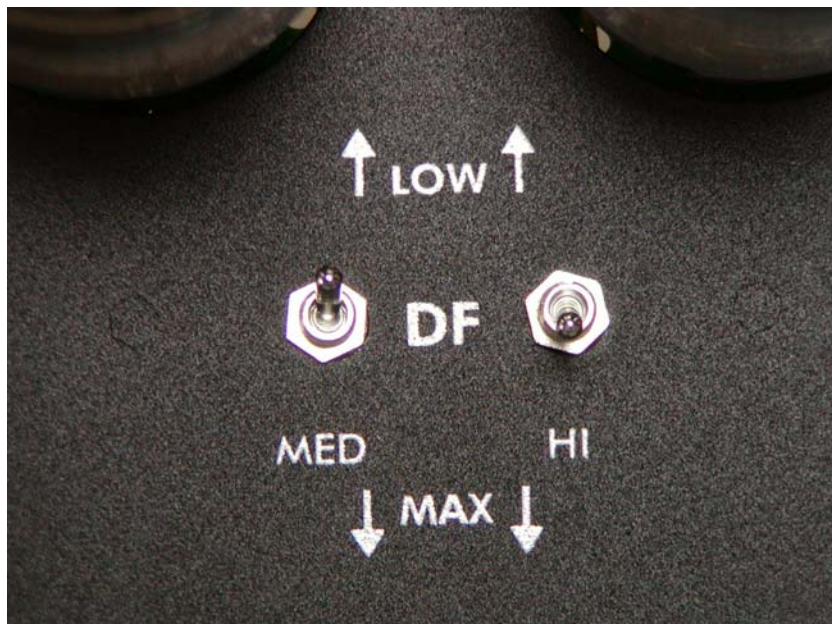

**HI DF Setting**



4. **MAX:** Both switches forward towards the front panel. This setting provides the maximum damping factor, but sonic impact could be noticeable.

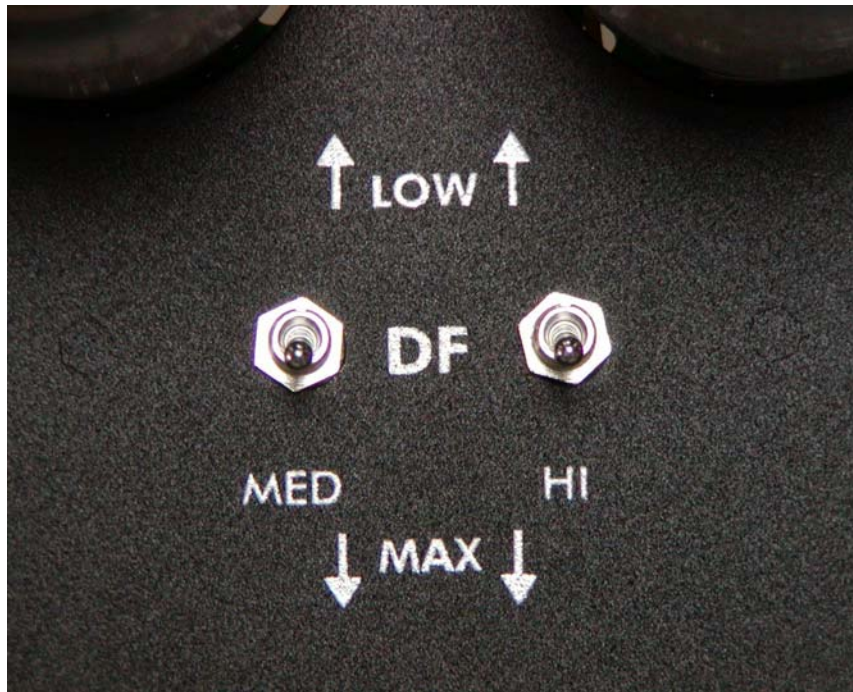

**MAX DF Setting**

## Remote Control and Communications

Using a 12V trigger to power the amplifier on or off

This amplifier is equipped with a 12V (AC or DC) input that can be used to power the amplifier on or off, if the rear AC rocker switch is in the ON position.

The connector used is a polarized Phoenix type female connector, for which males are readily available, and which is designed to prevent shorts during connection.

Triggers are used to power on/off the amplifiers from an outside source in the system, such as the preamplifier. Trigger outputs are typically 12 Volt systems (either AC or DC), connected via hardwired connection between components. The trigger input on this amplifier reacts to a holding voltage: When the trigger voltage is applied the amplifier will power up if the rear rocker switch is in the ON position, and when the hold is released, the amplifier automatically powers down.

In all cases the front panel power button takes precedence to power down. If the amplifier is powered on via the front panel button then applying the trigger voltage will not cause a change. If either the trigger voltage is released or the front panel power button is pressed the amplifier powers down. If the trigger voltage is left on, but the power button is pressed then the amplifier will power down, and will stay off unless the trigger voltage is cycled down and then back up.

### Using the Amplifier with an infrared Remote Control

This amplifier is designed to interface with industry standard remote control systems via the rear IR receiver. A remote wand is not supplied with the unit, but this capability can be added to your system by your professional installer via the remote code set supplied by the factory.

Once the remote interface is properly installed in your system, many of the remote functions can be accessed from a standard remote system. Currently the remote commands used by the matching TL7.5 preamplifier will access the following command functions:

- ➔ Power On/Off (rocker Power switch on the back of the amplifier must be up in the On position)
- ➔ Mute On/Off
- ➔ Tetrode/Triode mode switching

Further remote commands are available with additional programming, but since the IR port is only one direction, status information is not communicated back through the IR port.

### Using the amplifier with RS232 control

This amplifier comes with sophisticated bi-directional control and communication capabilities, where all the control and query functions can be performed remotely, and the amplifier's internal status information is communicated by its main microprocessor. The microprocessor also displays the amplifier's status information on the display window located at the center of the front panel, with the RS-232 offering further detail than can be represented on the front panel.

Control functions and information returned are accessed through the rear RS-232 port via a standard DB9 male female connector cable and standard ASCII text strings using pre-defined commands as listed below in the summary of all the control functions that can be performed on the front panel and the expected results on the display window and the RS-232 port.

The RS232 communication port is designed to interface with central command systems to enable the amplifiers to be located and operated remotely, and allows the user to interface with the amplifier using any PC and the standard HyperTerminal utility provided with the Microsoft Windows Operating system. Windows is configured using the Properties command under the File menu with the following settings:

9600 Baud, 8 data bits, Parity =None, 1 stop bit, Flow control =None

After the Hyper terminal Program is running and its Window is opened, enter the text string >HELP (or >?) followed by carriage return to display available commands. The convention used is command {parameter} or command [parameter], with {} meaning required parameters and [] meaning optional parameters. For systems without a return button the amplifier's microprocessor recognizes /C as a carriage return, and /R as a return. The input and output buffers can hold a maximum of 256 bytes at one time.

The user commands are:

Command	Meaning / Use	Expected response
>HELP or >?	For displaying a list of all available commands	All commands and their syntax

>STATUS	For querying the status of the amplifier	
>POWER {ON OFF}	For powering the amplifier ON and OFF	
>MUTE {ON OFF}	For Muting and Unmuting the amplifier	
>MODE [TRI TET]	For querying the mode, and selecting Triode or Tetrode modes	
>TOTLTIME	For displaying the total time the amplifier has been powered up, excluding standby time	
>TUBETIME [CLEAR]	For displaying powered up time since last reset, excluding standby time, and for clearing TUBETIME	
>ACINPUT [READ SET]	For displaying the AC Voltage input, and the internal AC Voltage setting of the amplifier	
>READTEMP {F C}	For displaying the unit temperature in degrees Fahrenheit or Celsius	
>PHASE	For querying the phase setting of the amplifier	>PHASE ZERO  >PHASE 180
>BIASLEDS {ON OFF}	For unsuppressing and suppressing the normal bias LED activity	
>COUNTDN {ON OFF}	For muting the power up countdown	
>TUBEFLT [CLEAR]	For querying tube fault status, and to clear a tube fault	
>TUBEBIAS [CLEAR]	For displaying the tube bias DAC values, and clearing stored DAC values	
>VTL	Returns factory contact info	Contact VTL:  Email: <a href="mailto:mail@vtl.com">mail@vtl.com</a>

		Tel. 909-627-5944 Fax. 909-627-6988
>VERSION	Returns the version number of the main display software.	
>VIEWERR	Displays the last 4 stored error messages, starting with the most recent events. When you enter >VIEWERR command again, the next 4 errors will be displayed and you can repeat >VIEWERR up to 4 times to see the last 16 errors stored in memory.	You can send the >VIEWERR command results to your dealer or to the VTL factory so that we can help you analyze the errors that had occurred in your amplifier.

## Diagnostic and programming Functions

This amplifier is a sophisticated component with a complete set of user features and controls. To get the most out of your new purchase it is strongly advised that you read and understand the following instructions, however it is not necessary to be able to perform or understand all of these functions for normal operation of the amplifier, as all critical operations are handled automatically. In all cases all of these functions are accessible remotely, and your authorized VTL installer dealer can perform them for you, either locally in your system or remotely.

The amplifier's internal status information can be accessed either by using a set of buttons located behind the *Diagnostic panel* or via the rear RS-232 port. To access the front panel buttons, hold the bottom of the inset *Diagnostic panel* with one hand, and carefully remove it using a 7/64" Hex wrench to loosen the two fasteners, gently pulling the small black panel insert towards you.

Six red buttons with corresponding LEDs are revealed, as well as the master processor. The master processor is socketed and can be updated with any new software versions or specially requested features. The diagnostic buttons are used for accessing all of the diagnostics that this amplifier is equipped with, allowing the user access to the most important operating features and controls.

WARNING: Be careful not to touch the master processor pins or any of the circuitry other than the buttons, as noise or static electricity can cause shut down and/or permanent damage. Before using the diagnostic buttons it is strongly recommended that you discharge your body by touching any exposed metal surface that touches the ground. Do not drag your feet across a carpeted surface, as this can build static charge.



### Basic Programming functions



These functions are user convenience functions, and are not critical to the amplifier's proper operation.



Function	Procedure	Indication
<b>Suppress Power on countdown display</b>	Press the MUTE button during power on countdown sequence to	Countdown timer display toggles between display and suppress display

<p><b>countdown display</b></p> <p>If unsuppressed the countdown timer displays the number of seconds remaining in the power on warm-up sequence.</p> <p>(Function only available during power up countdown sequence)</p>	<p>turn off the countdown display.</p> <p>RS-232: &gt;COUNTDN OFF</p> <p>Press Mute again during countdown sequence to turn the countdown display back on.</p> <p>RS-232: &gt;COUNTDN ON</p>	<p>with each press of the MUTE button during power on warm-up cycle.</p>
<p><b>Suppress normal Output tube LED activity</b></p> <p>Function turns off top deck output tube LEDs.</p> <p>(Function only available in operate mode.)</p>	<p>Press the MUTE button while holding down the TUBE BIAS button to turn the LEDs off.</p> <p>RS-232: &gt;BIASLEDS OFF</p> <p>Press the MUTE button while holding down the TUBE BIAS button to turn the LEDs back on.</p> <p>RS-232: &gt;BIASLEDS ON</p> <div data-bbox="532 1010 847 1461" data-label="Image"> </div>	<p>Top deck LEDs toggle between on and off.</p> <p><b>Note:</b> Only normal bias activity is suppressed, fault and tube identification is not suppressible.</p>

### Basic Diagnostic functions

The following basic diagnostic functions are for checking some operating parameters of the amplifier, if desired. These parameters do not need to be checked for the proper operation of the amplifier, as the amplifier continuously self-monitors and shuts down automatically in the event of any fault condition.

Diagnostic Function	Procedure	Indication
<p><b>Display Total time</b></p> <p>The total operating time of the amplifier, in hours.</p> <p>This function is accessible either in Standby mode or operating mode.</p> <p>Total Time cannot be cleared or reset by the user.</p>	<p>When user presses the TOTAL TIME button, the LED above the button turns on and the <i>Display Window</i> indicates the total powered on running time of the amplifier, in hours. A decimal point is added to the first display digit when the total time becomes five digits. For instance at 10,000 hours, the display indicates 1.000 A decimal in the second digit indicates 6 digits, ie 100,000 hours, and so on.</p> <p>RS-232 command: &gt;TOTLTIME</p>	
<p><b>Display Tube Time</b></p> <p>A resettable time log that the user can use to tell the amount of time that a set of tubes has been in the amplifier.</p> <p>This function is accessible either in Standby mode or operate mode.</p>	<p>When user presses this button, the LED above the button turns on and the Front panel display indicates the time since last reset, in hours.</p> <p>A decimal point is added to the display when the Tube Time becomes greater than four digits. For instance at 10,000 hours, the display indicates 1.000</p> <p>RS-232 command: &gt;TUBETIME</p>	
<p><b>Clear Tube Time</b></p>	<p>The user can reset the TUBE timer to track component usage, usually after each retubing, by holding down Tube time + Temp/Reset button simultaneously for 15 seconds, until the Display Window shows (--) to indicate that the clear command has been received.</p>	



	RS-232 command: >TUBETIME CLEAR	
<p><b>Display AC Voltage and AC Setting</b></p> <p>Indicates both the AC voltage setting of the amplifier as well as the AC line voltage input to the amplifier.</p> <p>This function is accessible either in Standby mode or operating mode.</p>	<p>In Standby mode, pressing the AC Voltage button displays the AC voltage setting of the amplifier (as preset by the factory) in the <i>Display Window</i>.</p> <p>RS-232 command: &gt;ACINPUT SET</p> <p>Holding this button for more than 5 seconds displays the AC line voltage input to the amplifier.</p> <p>RS-232 command: &gt;ACINPUT READ</p> <p>In operate mode, pressing the AC Voltage button displays the AC line voltage input to the amplifier.</p>	 <p><b>Note:</b> The amplifier continuously monitors AC conditions, and shuts down automatically under adverse conditions. (See fault indications later in this chapter.)</p>
<p><b>Temp</b></p> <p>Displays the temperature of the rear heatsink, either in degrees Celsius or Fahrenheit.</p> <p>This button has a dual function. When used alone, this button is a temperature button. When used simultaneously with some of the other buttons, it acts as a reset button. (See Fault section in this chapter.)</p>	<p>This function is accessible either in Standby mode or operating mode.</p> <p>RS-232 commands: Degrees Fahrenheit: &gt;READTEMP F</p> <p>Degrees Celsius: &gt;READTEMP C</p>	 <p>When the user presses this button, the LED above the button will be lit and the <i>Display Window</i> will display the amplifier temperature at the Power supply heat sink. The default temperature displayed is in Fahrenheit. To display the temperature in Celsius, hold down the button for more than 10 seconds.</p> <p><b>Note:</b> The amplifier automatically shuts down if the rear heat sink temperature reaches 60 degrees C, and when the temperature cools to 55 degrees C, the amplifier can be</p>

		powered on again. Under normal operation the heat sink should not reach 50 degrees C unless there is inadequate ventilation or very high power requirements for extended time periods. (See Fault Indications later in this chapter.)
--	--	---





### Advanced Functions and Diagnostics

These functions are for checking the condition of the output tubes, to determine life left. These critical functions are necessary for the continued optimum performance of this amplifier, and if the user is not comfortable operating them then the installer dealer or technician can perform these functions either locally or remotely.

Function	Procedure	Indication
<p><b>Display Tube Bias</b></p> <p>Displays the bias settings of each individual output tube.</p> <p>Bias settings are the first indicator of unmatched tubes, or aging tubes, as some tubes will require different bias than others, and tubes will require different amounts of bias as they age. Use this test to group tubes, as best performance is achieved when tube bias values are grouped together.</p> <p>For best results, perform this test after the amplifier has been in operate mode continuously for at least 1 hour.</p>	<p>This function is accessible in operate mode only.</p> <p>Mute the preamp to prevent music signal from coming through to the amplifier. (Muting the amplifier invalidates the tube bias test.)</p> <p>Pressing the BIAS button displays the tube number while the button is held down. That tube's bias setting is displayed for 2 seconds when the button is released. Pressing the button again displays the bias value of the next tube. Every time this button is pressed the tube number will increment, to rotate through the whole set of output tubes from 01 thru 12.</p> <p>RS-232 command: &gt;TUBEBIAS</p>	 <p>The corresponding top deck LED next to the tube being queried also flashes quickly while the BIAS button is held down, to identify the tube indicated on the front panel display.</p> 



**WARNING:** All connections and disconnection of cable to the amplifier should be done with the amplifier powered down and the main AC Rocker switch in the OFF position.

Function	Procedure	Indication
<p><b>Fuse Test</b></p> <p>A function to test whether any fuse is good or blown open.</p> <p>This amplifier is equipped with a fuse tester in the lower right corner of the Fuse/AC rear panel. There are two fuse holders, one larger and one smaller, and a switch labeled FUSE TEST. The Fuse test system and the two fuse holders are not part of the amplifier's protection circuitry, but are just connected to a low voltage sufficient to turn on the light if the fuse in either holder is good, and spare fuses may be kept in either holder.</p> <p><b>CAUTION: High voltages present. Do not remove any fuses while the amplifier is powered on. The fuse test must only be done while the amplifier is in standby mode.</b></p> 	<p>Be sure that sufficient space behind the amplifier is available so that the fuse test assembly can be accessed safely.</p> <p>Remove any fuses that may be inside either of the two fuse holders in the test area. The Fuse holders are connected in parallel, and so the test will be invalid if the user has fuses in both fuse holders.</p> <p>Note that there are two sizes of fuses in the amplifier. Remove the fuse to be tested from its original fuse holder, and install it in the appropriate sized fuse holder.</p> <p>To test either type of fuse, insert the fuse into the appropriate fuse holder, and press the momentary Fuse Test switch down.</p>	<p>If the fuse is good the light turns on when the switch is depressed, and if the fuse is blown the light will not turn on, indicating a fuse that needs replacement.</p> <p>Remove the tested fuse and only reuse it if the test result is good.</p> <p>Otherwise, a new replacement fuse is needed. Contact your authorized VTL dealer or the VTL factory for replacement fuses.</p> <p><b>CAUTION: High voltages present. For continued protection against risk of fire replace only with fuses of same type and rating.</b></p> 

<p><b>View Error Messages</b></p> <p>When a fault occurred in your amplifier and causes the amplifier to shutdown, you can find out more about the details of the error and the probable cause of the shutdown by displaying the contents of an error message buffer. Your amplifier is equipped with a buffer that can store up to 16 errors, and you can use the RS-232 command &gt;VIEWERR to display 4 error messages at a time.</p> <p>Please send the contents of &gt;VIEWERR command to your VTL dealer so that he/she can help you diagnose the cause of the fault. Please copy and paste the contents of the &gt;VIEWERR command from the Hyperterminal window and email this information to your VTL dealer.</p>	<p>Identify the fault that have just occurred and consult with the procedures in this Owner's Manual to clear the fault so that the amplifier is back to the Standby mode. You can either clear the fault by using the Diagnostic panel or the RS-232 commands.</p> <p>Next, connect your amplifier to your computer via the RS-232 terminal interface and open the Hyperterminal window.</p> <p>Verify that the Hyperterminal window is working properly by typing the "?" command to display a list of the RS-232 commands.</p> <p>Then enter the &gt;VIEWERR command into the Hyperterminal window. The most recent 4 error messages and relevant information concerning your amplifier will be displayed.</p> <p>Repeat this command 3 more times so that you can view up to 16 errors that have been stored away in the VIEWERR buffer.</p> <p>Copy and paste the entire contents of the &gt;VIEWERR commands and email this information to your dealer or to the VTL factory.</p>	
--	---	--

## Fault Indications

This amplifier uses a comprehensive fault sensing system to self-diagnose all critical operating areas, protect itself against faults and report fault conditions. The two main areas of fault are non-shutdown faults, and faults for which the amplifier must shut itself down.

Non-shutdown faults are non-critical faults, during which the amplifier can continue to operate for the rest of the listening session, but which should be attended to as soon as possible at the end of the listening session.

Critical shutdown faults are those which, if not attended to immediately could damage the amplifier, and they are divided into three main groups:- Tube red, Heat and Power.

Not ready modes

If the amplifier is not ready for power up (due to an external condition not rectified or fault not cleared) then the front panel display will indicate a flashing ----. In this condition the amplifier is not able to power up before the fault is cleared. In some cases the fault can only be cleared through some change in external conditions, and the amplifier may change its status in response to the new condition. In other cases the fault will need to be attended to by the user or the dealer's technician. In all cases the fault will be detected and the amplifier self-protected before any damage can occur.

### The possible faults (and clearing actions) are as follows:-

INVERTed Phase

The up-down PHASE switch on the rear panel of the amplifier allows for switching the amplifier between PHASE 180 (INVERT/out of phase) (down) and PHASE 0 (in phase) (up). In the down position the front panel text will indicate the steady red INVERTed phase, and the amplifier will be phase inverting from its input to its output.

The red INVERT text is off when the system is in the PHASE 0 state (in phase).

RS-232 command: >PHASE      Queries the phase setting of the amplifier.

TUBE green Fault

The Green TUBE text indicator indicates that an output tube has a non-critical fault, such as low (or no) current



Select between phases



draw. The tube could be either open or out of the socket, and the autobias system has been unable to bring it up to full power.

The tube number is displayed on the front panel display, and the top deck LED next to the indicated tube is blinking steadily to show the exact location of the tube. The steady blinking on the open tube will continue to blink while the amplifier is in the standby condition, or while music signal is present, where all the other LEDs are off.

This is a warning indicator only, and the amplifier can continue to operate without the need to shut down immediately, as balance across the output transformer is maintained with the system shutting off the

corresponding tube in the push pull pair. However the indicated tube should be changed as soon as possible, as in this condition output power will be lowered and sonic performance will be affected.

In the case of a second green tube indicator the amplifier will immediately shut down and will indicate a red TUBE fault, as the fault sensing system could otherwise become compromised under these conditions, and it is not recommended that the amplifier be operated with a green fault.



Green TUBE indicators, unit in operate mode

Check the output tube LED indicator on the amplifier deck to locate the tube that has the non-critical fault and follow the procedure described in Chapter 4 to replace that output tube.

#### TUBE red Fault

Where an output tube draws excessive current and cannot be controlled by the autobias system the amplifier



needs to be shut down and the faulty tube indicated on the front panel.

The flashing red TUBE indicator indicates that one of the output tubes has a critical fault that requires that the amplifier be immediately shut down to prevent damage to the amplifier circuits. In this condition the amplifier is in the standby mode with the LED indicators showing what to do to re-start the amplifier.

The tube number is displayed on the front panel display, and the top deck LED next to the indicated tube is blinking quickly to show the exact location of the tube. The steady blinking on the failed tube will continue to blink while the amplifier is in the standby condition, and all the other LEDs are off.

Check the output tube LED indicator on the amplifier deck to locate the tube that has the critical fault. Follow the procedure described in Chapter 4 to replace the output tube, and then clear the red TUBE fault light by performing the following procedure, informing the amplifier that the faulty tube has been replaced:-

### Reset Red Tube Fault

Remove the front panel Diagnostic cover and locate the buttons labeled TUBE LIFE and TEMP/RESET by looking at the flashing LEDs that show the buttons to be pressed to clear the fault. Hold down both buttons at the same time for 15 seconds until the front panel fault indicators turn off.

Located on the top rear panel of the amplifier are two rail fuses that act as a failsafe and will open if for some reason the fault sensing system does not catch the faulty tube before it draws excessive current. Before powering on the amplifier again check the Plate and Screen fuses to ensure that they are both good. See the Fuse test section in this chapter for a description of how to use the internal fuse tester to test the fuses.

Once the fault indicators have been cleared from the front panel the amplifier can be re-powered again using the POWER button on the front panel.

**WARNING: Do not attempt to clear the fault and re-power without first replacing the faulty output tube, as doing so could potentially damage the circuitry.**



If power to the amplifier is lost after a red tube fault shutdown and before the fault is cleared the fault is retained in memory until the next power up, where the fault will have to be cleared before power is allowed.

### HEAT Fault

Where there is inadequate ventilation or the amplifier is being driven hard such that the internal components are getting hotter than they are designed to run then the internal heat monitoring sensor will signal the amplifier to shut down, and remain shut down until the temperature returns to normal.

The flashing red HEAT light indicates that the amplifier is operating at a temperature that exceeds its safe operating limit. The amplifier is automatically shut down and the rear heat sink temperature is displayed in flashing numbers on the front panel display.

After the internal temperature of the amplifier goes back to the acceptable range (below 50 degrees C) the Heat LED turns off automatically, and the front panel displays the standby mode indication, a steady ----, indicating that the unit can be re-powered.



#### POWER faults

There are three different power faults: External Power supply faults (AC power), internal power supply faults not requiring service and internal power supply faults requiring service.

The amplifier automatically shuts down when it detects that either the AC voltage is higher or lower than the acceptable range or there is an internal power supply fault in the amplifier.

**AC fault:** In the case of over or under AC voltage the Power LED blinks and the front panel display shows the amplifier's blinking AC voltage setting. This automatically resets when the AC voltage returns to the correct range, regardless of whether power to the amplifier is lost or not, as the AC voltage sensing re-activates whenever AC power is applied to the amplifier.

When the amplifier's AC fault condition is removed, the front panel POWER light turns off and the display indicates a steady ----, indicating that the amplifier can be re-powered.

If the amplifier was on and shuts down, the steady red power light to indicate what happened. If amp was in standby mode, it will return to standby mode, when the AC supply returns to normal.

### AC Power supply fault shutdown, unit in standby mode

In the case of an internal power supply problem, there are two different conditions displayed:-

1. **Over-current fault:** An over-current fault indicates a temporary condition for which the amplifier has to be shut down to protect itself. In this condition the front panel red POWER light is on steady and the display indicates a steady ----, indicating that the amplifier can be immediately re-powered. If AC power is lost before re-power the red POWER light will turn off when power is re-applied.

2. Over Voltage fault: An over voltage fault indicates a permanent fault condition for which the amplifier has to be shut down to protect itself. In this condition the front panel red POWER light is flashing and the display indicates a flashing ---, indicating that the amplifier cannot be re-powered, and must be referred to a technician for service before re-power is allowed. If AC power is lost the fault condition is retained in memory and the red POWER light will be turned on whenever AC power is re-applied.



## Non-AC Power supply fault shutdown, unit in standby mode

### Tube Service Reminder

Tube condition dramatically affects performance, and is determined by testing and/or listening. Weak tubes sound tired and don't have the snap and punch they had when they were new. Every 3000 hours of TUBE TIME will display the green tube fault light with the number of hours in TUBE TIME on the front display.

This number is a median expected tube life, and can vary by user. In some cases tubes will last less than this time, and in some cases longer, depending upon power levels that the amplifier is operated at. The service reminder is used to remind the user to check the condition of the output tubes with a quantitative test, and then replace any faulty, gassy or weak tubes.

We recommend that the tubes be replaced when the reminder is displayed and then the service indicator can be re-set, and it will reappear after the next 3000 hours to remind the user to do the tube check tests again.

## Reset / Clearing faults

### Fuse Tester

This amplifier is equipped with a fuse tester in the lower right corner of the Fuse/AC rear panel. There are two fuse holders, one larger and one smaller, and a switch labeled FUSE TEST. The Fuse test system and the two fuse holders are not part of the amplifier's protection circuitry, but are just connected to a low voltage sufficient to turn on the light if the fuse in either holder is good, and spare fuses may be kept in either holder.

To test either type of fuse, insert the fuse into the appropriate fuse holder, and press the momentary *Fuse Test* switch down. If the fuse is good the LED will light when the switch is depressed, and if the fuse is blown the LED will not light, to indicate a fuse that needs replacement.





**CAUTION: High voltages present. The Fuse test must only be done while the amplifier is in standby mode.**

**CAUTION: High voltages present. For continued protection against risk of fire replace only with fuses of same type and rating.**



<p><b>Clear TUBE Red Fault</b></p> <p>Perform this function after a critical tube fault has been detected and you have replaced the faulty tube.</p> <p>Perform this function in Standby Mode only.</p>	<p>Simultaneously hold down the TUBE LIFE and TEMP/RESET button for 15 seconds.</p> <p>RS-232: &gt;TUBEFLT CLEAR</p>	<p>Indication: (--)</p>
<p><b>Clear saved Tube Bias Settings</b></p> <p>Perform this function every time you change any tubes in the amplifier, or whenever the position of the tubes is changed around.</p> <p>When a critical Tube fault is detected and you have changed the faulty tube, you must perform the Clear Tube Bias function as well.</p> <p>This function can be performed in Standby Mode only.</p>	<p>Simultaneously hold down the TUBE BIAS and TEMP/RESET button for 15 seconds</p> <p>RS-232 command: &gt;TUBEBIAS CLEAR (Unit must be in standby mode.)</p>	<p>Indication: (--)</p>
<p><b>Clear Tube service reminder</b></p>	<p>Simultaneously hold down the TUBE TIME and TEMP/RESET button for 5 seconds.</p>	<p>Indication: tube time and green fault disappear</p>
<p><b>Clear tube time</b></p> <p>Perform this function to clear the total tube hours after you replace a new set of tubes in the amplifier.</p> <p>Perform this function in Standby Mode only.</p>	<p>Simultaneously hold down the TUBE TIME and TEMP/RESET button for 15 seconds</p> <p>RS-232: &gt; TUBE TIME CLEAR</p>	<p>Indication: (--)</p>

## Powering the amplifier off

You may keep your VTL amplifier in the Standby mode and your source components on permanently if you prefer to keep the source components warm. If you prefer to keep all your equipment off when not in use, then it is best to follow the correct turn off sequence to avoid power off thumps through the system.

When you're done listening to your system always turn all power amplifier(s) off first Then turn the source components off, if you prefer to keep these off when not in use.

**WARNING: Do not power the amplifier off from the rear rocker switch, as all settings will be lost to memory. If possible only power off through the following reset methods:-**

- Press the POWER button on the front panel.
- If using the automatic trigger turn on/off system then power off the preamplifier, which will automatically power the amplifier(s) off.
- If using a central remote control system connected to the RS-232 port then issue the Power off command.
- The unit immediately begins power down and displays ---- and discharges high voltage power supplies. Last used modes are saved for next power up

RS-232 command: >POWER OFF

To avoid unplanned power ups turn the rear panel power rocker switch to OFF position if you don't plan to use the amplifier for an extended period of time.

# Care and Maintenance of your VTL amplifier

## Break In Period

Your VTL amplifier is designed to give you the continued optimum performance over an extremely long time period. Initially the tubes and circuits will require a burn-in period to reach maximum performance. During the first 100 hours of usage the amplifier will undergo several improvements in sound. To break in the amplifier you can leave it on with a music source connected to it and playing with the volume control turned to low level. Do not leave the amplifier on if you are not home.

## Tube Life

Your VTL amplifier has been designed to ensure long tube life. Total tube life lasts on the average about 3000 hours (3 to 5 years under normal use.) Your amplifier is designed with a logic controlled automatic tube biasing and fault sensing system and two manual diagnostic mechanisms, i.e. TUBE TEST and TUBE BIAS, to detect weak and defective tubes. Please follow the procedures written in this manual to determine when the tubes in your amplifier should be replaced.

We recommend a complete replacement of all tubes in your amplifier after 3000 hours of usage, which will restore the amplifier to a “like new” sound quality. The TUBE TIME diagnostic function is designed to inform you of the cumulative hours your tubes have been in use since the last replacement. When the total Tube Time reaches 3000, the TUBE GREEN LED bar will light up, and the *Display Window* will show the number “3000.” This serves as a reminder that you should change your entire set of tubes and after the change, reset your TUBE TIME counter back to 0.

To reset the TUBE TIME counter, hold down TUBE TIME + TEMP/RESET button simultaneously for 15 seconds, until the Display Window shows (--) to indicate that the counter is cleared to 0.

The tubes used in your SIEGFRIED Reference Amplifier are specially matched and tested for this amplifier. Please contact your VTL dealer or VTL factory service department to order the matched tubes for your replacement.

**Warning:** Tubes can be variable and some types will not yield the best performance or reliability in this amplifier. Please contact your VTL dealer or the VTL factory to purchase matching tubes for your amplifier.

**WARNING:** use only tube types and tube brands that are recommended by VTL. VTL specified replacement tubes are available from your authorized VTL dealer or the VTL factory service department. Any damage incurred to units which use non-VTL approved tubes will not be covered under the warranty.

## Changing Tubes

If the amplifier displays a tube fault (either Tube Green or Tube Red fault,) you should replace the faulty tube according to the tube number displayed on the Display Window. Also if the results of the TUBE BIAS test indicates that a tube is not operating within the recommended range, you should also replace those tubes as well .

Read the following procedures before changing tubes in your amplifier. If you do not feel comfortable doing the procedure yourself, please contact your authorized VTL dealer or the VTL factory service department and request the service to be performed by a trained technician.

Warning: Lethal voltages and high, internal temperatures. Under no circumstances should the amplifier be operated without the cover.



Open the protective cover: Re-tubing the VTL amplifier requires the removal of the amplifier cover, which can expose potentially lethal voltages. Be sure to only touch the tubes themselves, and do not allow any part of your body or hanging jewelry to come into contact with any part of the circuit inside the unit.

### Removing the top cover to gain access to the tubes.

When the amplifier was first shipped from the factory, the top cover was installed with locking screws. The screw should be removed by the customer for easy access to the tubes inside the amplifiers.

User input: The top cover of the amplifier is fitted with three long screws in three strategic locations along the top cover. To remove the top cover, the user need to remove these three screws. (See Fig. 7). After the three long screws are removed, gently lift up the top cover. Enclosed in the customer care package are three shorter replacements screws. Install these three shorter screws to replace the three removed screws. This shorter screw will allow the user to remove or replace the top cover without using any tool in the future.

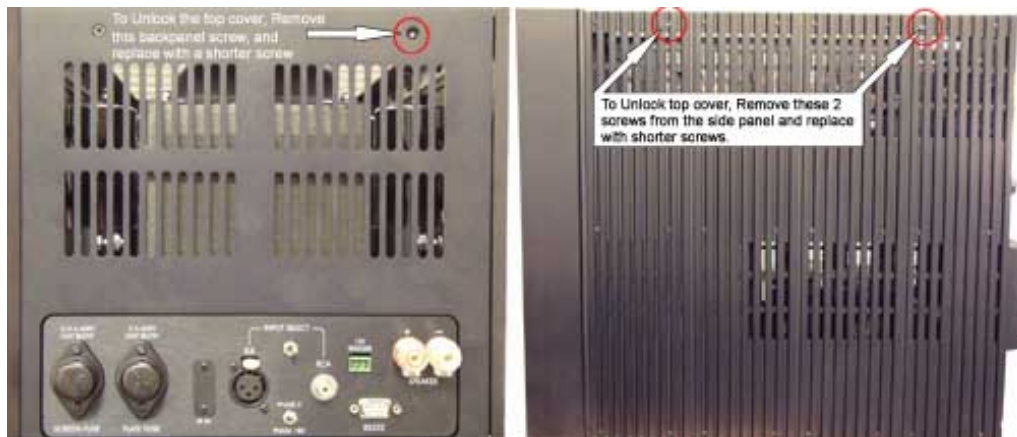

### Locations of the Top Cover Screws on the back and side of the Amplifier

Status: Save the three long screws. The user will need to replace the three newly install short screws with the three long screw to lock the top cover before shipping the unit.



For the dealer's service technician only

Opening the protective cover: Re-tubing your VTL amplifier requires removal of the covers, which can expose potentially lethal voltages. Be sure to only touch the tubes themselves, and do not allow any part of your body or hanging jewelry to touch the inside of the amplifier.

1. Diagnose the tubes: If you are not undergoing a complete retube for the entire amplifier, then you must first decide how many tubes and which tubes should be changed. Use the Tube Bias test to determine whether they are within an acceptable range is strongly recommended. Write down the tube number(s) that need to be replaced. (Go to Chapter 3 Advanced Functions and read the Tube Bias test procedures.)



2. Power off the amplifier: To change tubes in this amplifier you should first power the unit down, turn off the Power rocker switch from the rear panel, and unplug the unit from the wall outlet. Let the amplifier stay powered off for at least 15 minutes before working with it. Make sure the tubes are cool before you touch them. Carefully remove the top cover and store it in a safe place. (See the procedure in the previous page on how to remove the top cover if you have never removed it before).



3. Removing Tubes: Using the tube number that you have written down, locate the tube you need to remove. You can refer to the following picture for the tube numbering system on the amplifier's deck. Hold onto the upper portion of the tube towards its tip, and be careful not to bend the tube pins, gently and in small amounts rotate and rock the tube with your fingers to loosen it from its socket until its pins are completely disengaged from the socket. Take the tube out of the unit.





4. Plugging in a new tube: Hold onto the upper portion of the tube towards its tip. Lower the tube onto the socket, making sure that the pins from the tube match the holes in the socket.

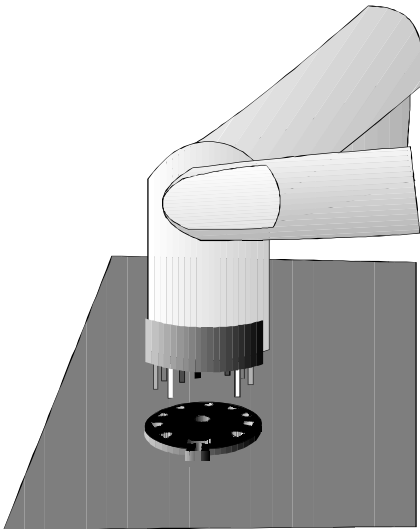

5. For the smaller input tube, there are two pins on the tube, which are spaced at a wider distance from each other than the rest of the pins (9 pin miniature tubes). Press the tube firmly into its socket, using a gentle force and a slight “rocking” motion. When the tube is properly and completely inserted into the socket it should be firmly seated and does not give in to any movement at all when you try to rock it gently. If the socket appears loose and not making contact with any or all of the tube pins, contact VTL for help.

6. For the larger Power tubes, there is a locating pin in the middle of the tube (8 pin octal tubes). Make sure that these locators go into the side of the socket that matches. Press the tube firmly into its socket, using a gentle force and a slight “rocking” motion. When the tube is properly and completely inserted into the socket it should be firmly seated and does not give in to any

movement at all when you try to rock it gently. If the socket appears loose and not making contact with any or all of the tube pins, please contact VTL for help.

7. Replacing the protective cover: Lower the top cover slowly back onto the top of the amplifier, making sure that the cover is put on in the correct front and back position and that the cover is securely fastened to the unit.
8. Reconnect the AC power cord, and power on the unit from the Power On rocker switch on the rear.
9. Reset the Red Tube Fault if fault exists: If the Red Tube fault LED is on and flashing due to a tube fault, then you must reset the fault to inform the amplifier that a new tube has been replaced. Remove the front panel Diagnostic cover and locate the buttons labeled TUBE LIFE and TEMP/RESET by looking at the flashing LEDs that show the buttons to be pressed to clear the fault. Hold down both buttons at the same time for 15 seconds until the front panel fault indicators



turn off and the display shows “----“ indicating that the amp is in Standby mode . See Chapter 3 the section on **Reset Red Tube Fault** for more details.

10. Power on the amplifier from the Standby Mode to the Operating mode by touching the Power button on the front panel. The amplifier starts its countdown sequence and resets and rebiasés all of the tubes in the amplifier from the default value.
11. After the amplifier is powered on and the Mute LED is off, the Output tube LEDs should be steady with just occasional blinking indicating that the tubes are in optimum bias range.

Congratulations! You have successfully replaced new tubes in your amplifier.

## Changing the Screen, Plate, Logic, B+ Input, Filament Fuses

The Amplifier comes with a built in Fuse Tester. To use this fuse tester, the unit must be in Standby only. Please refer to the Section on Advanced Functions and Diagnostics in Chapter 3 for the details on how to use the Fuse Tester to test whether a fuse is working or not.

The Screen fuse is rated at  $\frac{3}{4}$  A fast acting 600V fuse. The Plate Power supply fuse is rated at 5A. fast acting 600V fuse. There is also one Logic AC fuse rated at 1.0A Slo Blo (100/120Volt, 220/240V AC). The B+ AC is rated at 20A Slo Blo (100/120Volt AC) or 10A Slo Blo (220/240 Volt AC) ceramic. The input and filament AC fuses are rated at 2A Slo Blo (100/120Volt AC) or 1A Slo Blo (220/240 Volt AC) ceramic.

There is also a non-user serviceable Raw B+ fuse housed in a PC board mounted fuse holders located inside the audio unit. This fuse is to be service only by an authorized service Technician.

To change the AC fuse first ensure that the unit is powered off, and disconnect the AC power cord from the unit. Move the amplifier so that you can work with the panel in the back of the amplifier chassis.

The type of fitting used for the fuses is called a bayonet fit, which describes the action needed to remove the fuse cap. Locate the Main fuse holder, and loosen it by inserting a flat head screwdriver into the slot and turning the screw head approximately one quarter of a turn in a counter-clockwise direction while pressing inwards. The fuse cap should spring out from its housing with the fuse held inside the cap. Take the fuse out and replace it with a new one, and insert the fuse cap back into the holder, pushing it downward while turning it in the clockwise direction to lock it in place. Use the same procedure to replace the output stage protection fuses.



**WARNING:** For continued protections against fire hazard only replace the fuse with the same type and rating as was specified for the amplifier by the VTL factory. If you have problems locating the correct fuse contact your VTL dealer or the VTL factory service department.

**WARNING:** Before powering on the amplifier after a fuse change, it is extremely important to find the problem that caused the fuse to blow in the first place. Consult your dealer or the VTL factory and inform them of the fuse problem.



## Cleaning

Your VTL amplifier can be dusted occasionally with a damp non-abrasive cloth. You should not use any solvents for cleaning the front panel, as this can damage the lettering and the finish.

## Troubleshooting

1. When I power on the amplifier from the rear rocker switch, nothing happens. What should I do?

Check to make sure that the power cord is properly connected to the amplifier's Power AC inlet as well as the AC outlet from the wall. If there is no problem with the power source, check the fuse unit in the back panel of the amplifier with the Fuse Tester in the back of the amplifier. (See the section on Advanced Functions and Diagnostics in Chapter 3 for details on how to test the fuse using the Fuse Tester.) If the fuse is blown, replace it with a new fuse, and try turning the power on the amplifier again. If the problem still persists, contact your authorized VTL dealer or the VTL factory immediately.



2. When I try to power on the unit with either the remote control or the front panel, the *Display Window* shows blinking numbers such as 120 or 240. What is the problem?

Check to make sure that the amplifier's voltage setting matches with your AC line voltage. Locate the AC Voltage test button hidden behind the Diagnostic cover on the Front Panel and press that button. The *Display Window* will display the AC voltage setting of the amplifier (as preset by the factory.) If you hold this button for more than 5 seconds, the *Display Window* will show the incoming AC voltage from your AC line.

If your amplifier's AC voltage setting matches with the line AC voltage but the problem still persists, then contact your authorized VTL dealer or the VTL factory.

3. I am getting a noise and hum coming from my speakers when I turn the amplifiers on. What can I do to eliminate the noise?

It is recommended that you connect your audio components as possible to a good clean AC ground in your system, and for quietest operation it is recommended that all components be plugged into the same ground potential (or same AC outlet.) In single ended mode a ground loop hum can result from a difference in ground potential between different components in the system and it is recommended that the system be operated in the balanced mode to defeat ground loop problems. Under no circumstances should you attempt to defeat the ground with a ground lifter cheater plug, as serious damage to the components and yourself could result. If the noise persists you should either contact your dealer or the VTL factory to try to resolve this problem.

4. I am getting a noise and hum coming from my system when I plug in a video source. What can I do to eliminate the noise?

The noise may be coming in from your video cable system. First disconnect the VCR from the system to see if this will solve the problem. If it does then you will need to try to lift the ground from the cable TV wire by means of a cable ground-lifting transformer available from most electronics stores. If the problem still persists contact your VTL authorized dealer or the VTL factory service department.

5. I am getting a ringing noise from the amplifier when I touch or bump it. What should I do?

One or more of the tubes in the amplifier may be microphonic and the source of the problem. Follow the procedures listed in this manual to remove the tubes and change them for new ones.

6. When I try to power the amplifier up I get a POWER fault shutdown, or I get power up, but no output. What is the problem?

One or both of the rail fuses might be blown for some reason, which can happen when there is a power surge or when an output tube fails, as sometimes the fuse blows before the fault sensing can complete the amplifier shutdown. Check the fuses in the rear panel Fuse tester, and replace the blown one and try to re-power. If the problem persists then contact your authorized VTL dealer or the factory.

7. I cannot clear the POWER fault light, and the amplifier won't let me power it up. What is the problem?

If RS-232 control is attached to the amplifier try checking the message displayed. If it says Over Voltage fault then the amplifier has an internal power supply fault in the regulator, which cannot

be rectified internally and requires repair by a service technician. After repair the technician will also reset the processor so that the unit can be powered up again.

# Specifications

Vacuum Tube Complement	1 x 12AT7, 2 x 12BH7, 12 x 6550 or KT-88
Output Power 20 Hz – 20kHz, into 5 ohm load	Tetrode 650W, Triode 330W
T.H.D. 20 Hz – 20 kHz @ 750W Tetrode T.H.D. 20 Hz – 20 kHz @ 375W Triode	< 2.5% < 2.5%
Inputs	Balanced XLR (1), Single ended RCA (1)
Output	5-way Binding Post (1 pair)
Class of output operation	AB1
Optimal Load Range	4 - 8 ohms
Input sensitivity	Variable between 1-2V, depending upon DF setting
Input impedance	47K Ohms
Balanced Input Common Mode Rejection Ratio	60 dB
S/N Ratio @ 750 W Tetrode S/N Ratio @ 375 W Triode	-110dB, 120 Hz
Power consumption	Idle = 600 W Full Power = 1500 W
Secondary DC Volt Fuse Ratings	Plate 5A Fast 600V Screen 3/4A Fast 600V
AC Fuse ratings	Logic: 1.0 Amp Slo Blo 120V, 220V, 240V B+: 120V 20 Amp Slo Blo, 240V 10 Amp Slo Blo Input: 120V 2 Amp Slo Blo, 240V 1 Amp Slo Blo Filament: 120V 2 Amp Slo Blo, 240V 1 Amp Slo Blo
Dimensions W x D x H	11.5 x 24 x 24 inches (29 x 61 x 61 cm)
Weight Shipping Weight	Net: 205 lbs/95 kg 300 lbs/135 Kg, per monoblock per crate.

	Crate Dimensions: 34 x 20 x 36 inches
--	---------------------------------------

# Warranty

Your VTL amplifier/amplifier is covered by a limited warranty against defects in materials and workmanship for a period of 90 days from date of purchase by the original purchaser only when purchased from an authorized VTL dealer only. A further optional limited non-transferable five-year warranty is available to the original purchaser only upon proper registration of ownership within 30 days of date of first purchase. The warranty period begins on date of first sale to the end user, or one year after shipment from the VTL factory, whichever is the earlier.

Proper registration is made by filling out and returning to the factory the warranty card attached to this general warranty statement, along with a copy of the original sales receipt as proof of the original date of purchase, within 30 days of purchase. Only one registration card is issued with each unit. If the warranty registration card has already been removed then this is not a new unit, and is therefore not warranted by the factory. If you believe this to be a new unit then please contact the factory with the details of purchase.

This warranty is provided by the dealer where the unit was purchased, and by VTL Amplifiers Inc. Under the terms of the warranty defective parts will be repaired or replaced without charge, excepting the cost of tubes. A six-month warranty on tubes is available with the correct recording of the serial number of the amplifier on your warranty registration card and mailing it with your purchase receipt to VTL.

If a VTL product fails to perform properly under the above warranty then the purchaser's sole remedy shall be to return the product to the authorized VTL dealer or to VTL Amplifiers Inc, where the defect will be repaired without charge for parts and labor. The product will then be returned via prepaid, insured freight, method and carrier to be determined solely by VTL Amplifiers Inc. All returns to the factory must be in the original packing and accompanied by a Return Authorization, (new packing will be supplied for a nominal charge if needed), accompanied by a written description of the defect. This must be shipped to VTL Amplifiers Inc via insured freight at the customer's own expense. Charges for unauthorized service and transportation costs are not reimbursable under this warranty, and all warranties, express or implied, become null and void where the product has been damaged by misuse, accident, neglect, modification, tampering or unauthorized alteration by anyone other than VTL Amplifiers Inc., including the use of non-factory approved tubes.

This warranty applies only to units used in residential non-commercial use. The warrantor assumes no liability for property damage or any other incidental or consequential damage, whatsoever which may result from failure of this product. Any and all warranties of merchantability and fitness implied by law are limited to the duration of the expressed warranty. All warranties apply only to VTL products purchased and used in the USA.

Some states do not allow limitations on how long an implied warranty lasts, so the above limitations may not apply to you. Some states do not allow the exclusion or limitation of incidental or consequential damages, so the above exclusion may not apply to you.

This warranty gives you specific legal rights and you may also have other rights that vary from state to state.

## Appendix I: Quick Reference - Summary of indicators

Indicators and displays:

**Off:** No display

**Standby, not ready for power up:** Slow flashing ----, relevant red LEDbar and relevant diagnostic LED lit (see Fault section)

**Standby, ready for power up:** Steady ---- with no other lights lit

**Triode mode:** Red MODE light

**Tetrode Mode:** Green MODE light

**Power up:** Blinking blue POWER light, 240 to 000 countdown on display (if not suppressed) with MUTE light flashing. Steady 000 (if not suppressed) and flashing blue POWER light if biasing not yet completed, and MUTE light blinking

**Power on:** Steady blue POWER light

**Muted:** Steady red MUTE light

**Unmuting:** Blinking red MUTE light

**Tube Biasing:** Steady or Flickering green light (if not suppressed) on top deck next to each tube.

**Tube not biasing:** All top deck tube lights off, indicating amp is receiving signal.

**Phase inverted:** Steady red INVERT lighted text

**Non-critical tube fault:** Steady green TUBE lighted text, relevant tube number (01 to 12) on display, slow blinking green LED on top deck by tube corresponding to number on display, tube light turned off for corresponding tube on other phase biased to cutoff.

**Critical tube fault:** Slow flashing red TUBE lighted text, relevant tube number (01 to 12) on display, fast blinking green light on top deck by tube corresponding to number on display.

**Overheat:** Slow flashing red HEAT lighted text and flashing ---- display to show re-power not allowed until safe temperature reached. (HEAT text extinguished and steady ---- when temperature drops to safe level, to indicate re-power allowed)

**Power supply faults:** Slow flashing red POWER lighted text on front panel, and relevant display

- **AC power supply fault:** Incorrect AC voltage (low or high): Alternately flashing AC voltage setting and ---- to indicate power up not available until correct voltage sensed.

### Regulator fault modes:

- **OC (over current) (Plate or Screen)** Flashing red POWER lighted text and steady ----, to indicate immediate re-power available.
- **OV (over voltage)** Slow flashing red POWER lighted text and ----, with re-power not allowed until technician re-set after repair.
- **Regulator current shift fault:** Steady red POWER lighted text as regulator drops out of current shift and immediate shutdown, and slow flashing red POWER lighted text and steady ---- when shut down to indicate immediate re-power available.

### Diagnostic LEDs:

- **Total Time** (Operate or standby modes): Not re-settable. Press to show total amp on time.
- **Tube time** (Operate or standby modes): Press to show tube time. Reset with retube by holding down TUBE TIME and RESET buttons for 15 seconds until clear response (-) from display.
- **Service Reminder** Green TUBE led bar and TUBE TIME led after every 3000 hours of TUBE TIME, at each successive 3000 hour interval to remind the user to check the tubes and re-tube if necessary.
- **AC voltage display:** (Operate mode) Press to show AC voltage at supply. (Standby mode: Press to see pre-defined AC voltage setting in EEPROM)
- **Bias display** (Operate mode only): Press to show bias setting for each tube. Top deck led flashes super fast and tube number (01 to 12) shows on display to identify tube. Bias readout then shows on display for 2 seconds. The bias button led comes on when the bias button is pressed.

Reset stored bias values (during standby mode only) with retube by holding down BIAS and RESET buttons for 15 seconds until clear response (--) from display.

- **Temperature display** (Operate mode only): Press TEMP/RESET button to show temperature for 2 seconds. (In degrees Celsius or Fahrenheit.)

**Resets:**

- **Tube time** (Standby mode only): Reset with retube by holding down TUBE TIME and RESET buttons for 15 seconds until clear response (--) from display.
- **Service reminder** (Operate mode only): Reset by holding down TUBE TIME and RESET for 5 seconds until TUBE green led bar and TUBE TIME on 7 seg display turns off.
- **TUBE LIFE** (Standby mode only) Clear tube fault stored value by holding down the TUBE LIFE button and the RESET button for 15 seconds until clear signal (--) received from 7 seg display.
- **Stored Bias Values** (Standby mode only): Reset with retube by holding down BIAS and RESET buttons for 15 seconds until clear response (--) from display.

## Appendix II: Individual tube hour log

This sheet may be used for logging individual tube hours if the user should require to. Note the position number and total time on first installation of the tube. To find the amount of time that tube has been in the amplifier for then subtract that number from the current total time.

<b>Tube Number</b>	<b>Total Time when tube was Installed</b>	<b>Total Time Tube has been in use = Current Total Time – Install Time</b>
1		
2		
3		
4		
5		
6		
7		
8		
9		
10		
11		
12		



## Warranty Registration

Warranty registration for VTL products is valid in the USA only. International VTL customers should consult their local VTL dealer regarding product registration and warranty procedures.

To obtain valid US warranty service, please fill out the enclosed VTL Warranty Registration card and mail it to the following address with a **copy of your original bill of sale** within the first thirty days of purchase:

**VTL Warranty Registration**  
**4774 Murrieta Street, Suite 10**  
**Chino, CA 91710**  
**USA**

To help you keep a record of the serial number and purchase information, please enter the following information into this manual.

**Product Model Number:** \_\_\_\_\_

**Serial Number:** \_\_\_\_\_

**Purchase Date:** \_\_\_\_\_

**Authorized Dealer:** \_\_\_\_\_

### Service Notes

Date	Service	Initials
_____	_____	_____
_____	_____	_____
_____	_____	_____
_____	_____	_____
_____	_____	_____
_____	_____	_____